

Class 15

Data Systems on Modern Hardware:
Multi-cores, Solid-State Drives, and Non-Volatile Memories

Tarikul Islam Papon

<https://bu-disc.github.io/CS561/>

Compute, Memory, and Storage Hierarchy

Traditional von-Neuman computer architecture

- (i) assumes CPU is fast enough (for our applications)
- (ii) assumes memory can keep-up with CPU and can hold all data

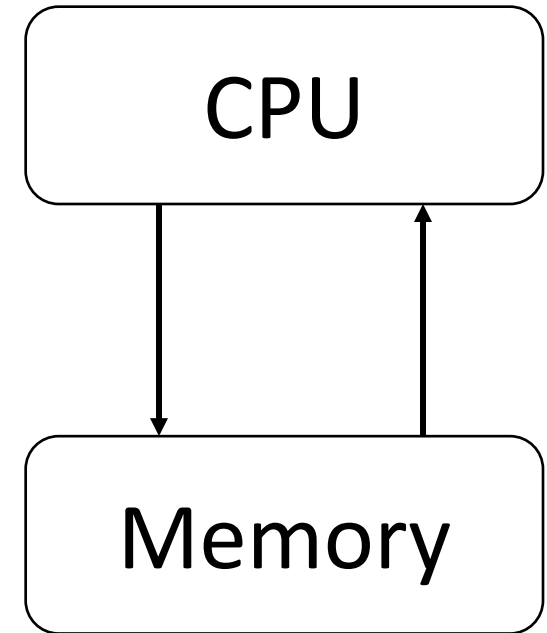

is this the case?

*for (i): applications increasingly complex, higher CPU demand
is the CPU going to be always fast enough?*

Moore's law

Often expressed as:

“X doubles every 18-24 months”

where X is:

“performance”

CPU clock speed

the number of transistors per chip

which one is it?

Moore's Law is Alive and Well! Transistors per Square Millimeter by Year

but ...

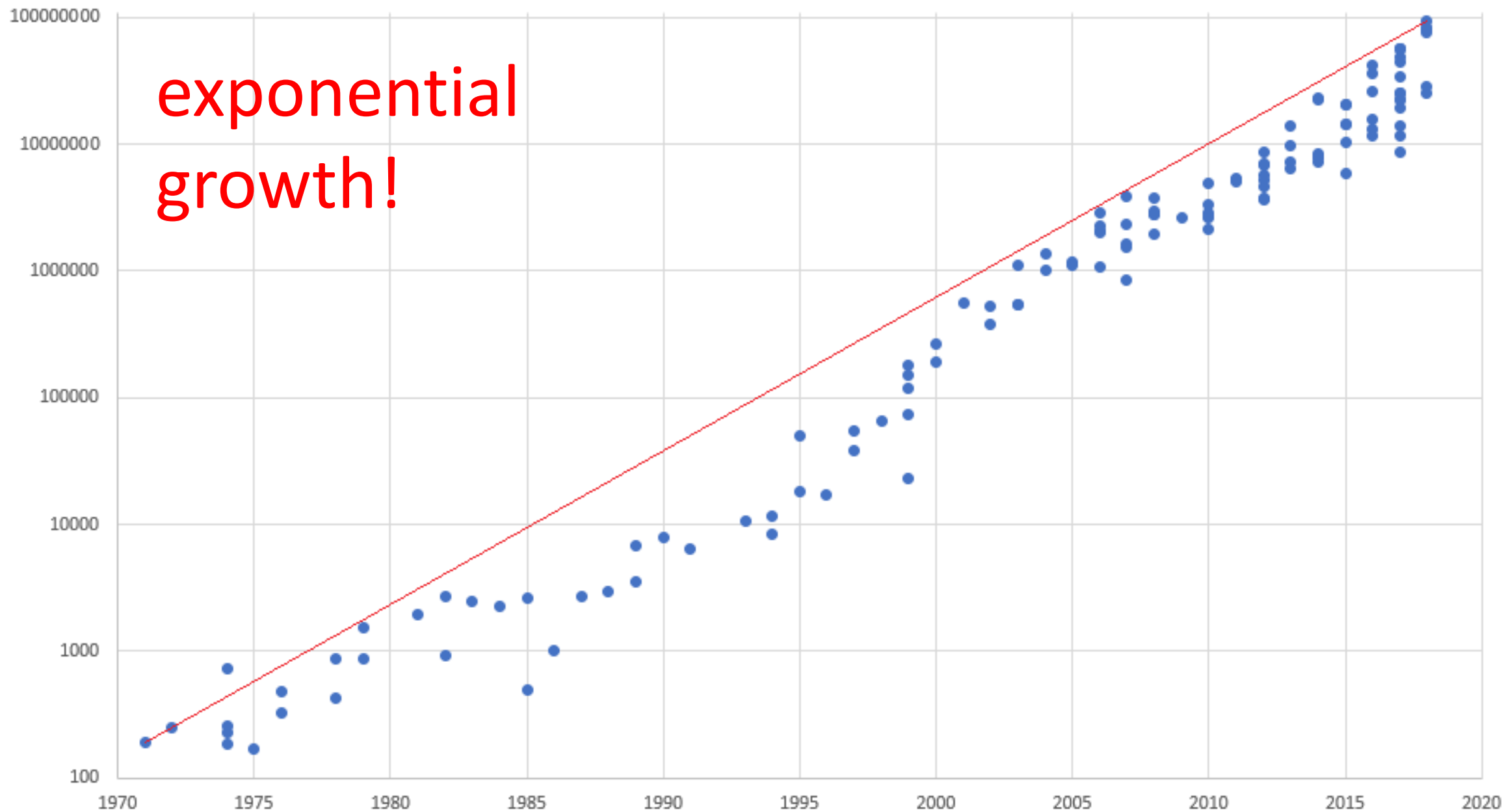

40 Years of Microprocessor Trend Data

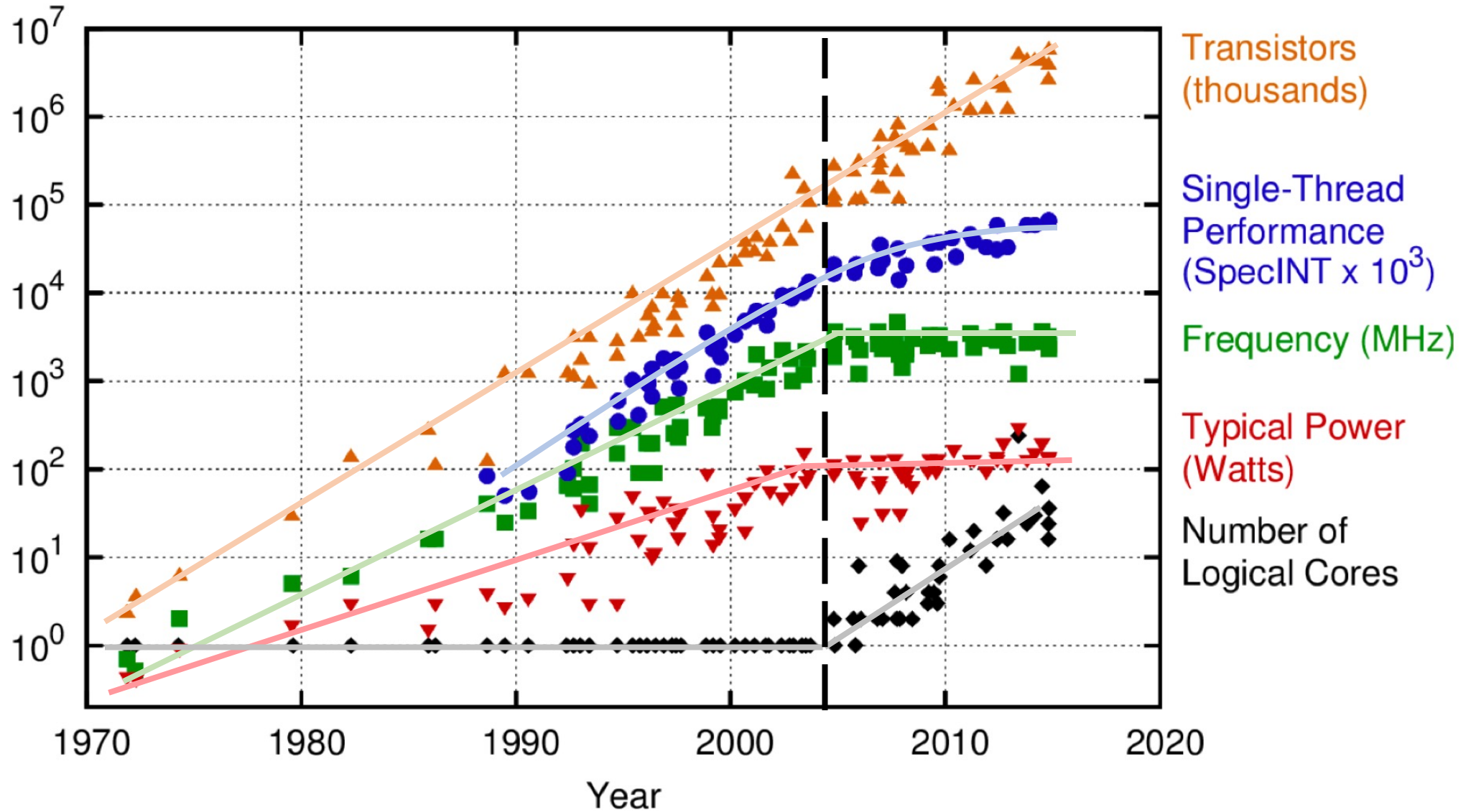

Original data up to the year 2010 collected and plotted by M. Horowitz, F. Labonte, O. Shacham, K. Olukotun, L. Hammond, and C. Batten
New plot and data collected for 2010-2015 by K. Rupp

Can (a single) CPU cope with increasing application complexity?

No, because CPUs (cores) are **not** getting faster!!!

.. but they are getting more and more (**higher parallelism**)

Research Challenges

how to handle them?

how to parallel program?

Compute, Memory, and Storage Hierarchy

Traditional von-Neuman computer architecture

- (i) assumes CPU is fast enough (for our applications)
not always!
- (ii) assumes memory can keep-up with CPU and can hold all data

is this the case?

for (ii): is memory faster than CPU (to deliver data in time)?

does it have enough capacity?

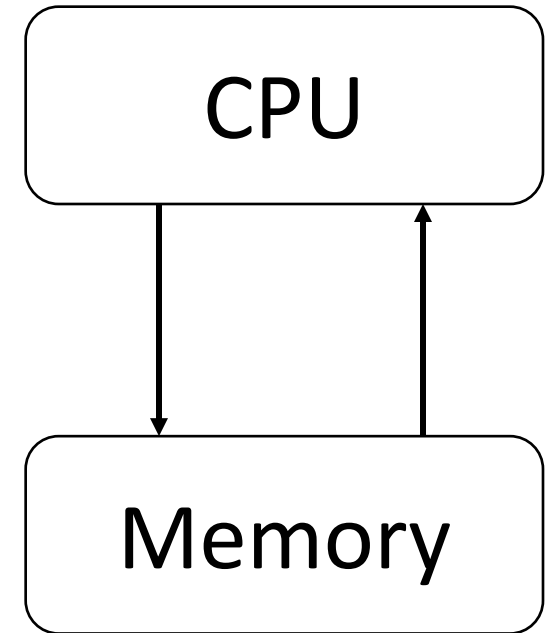

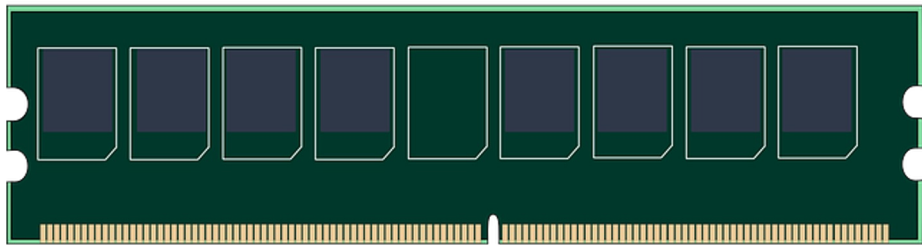
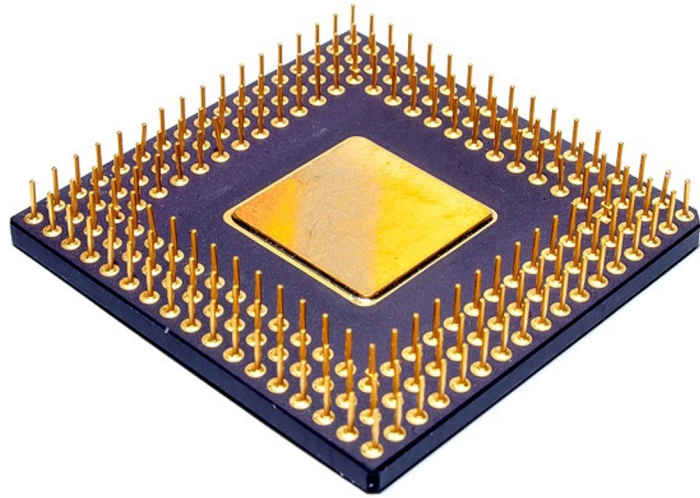

Which one is faster?

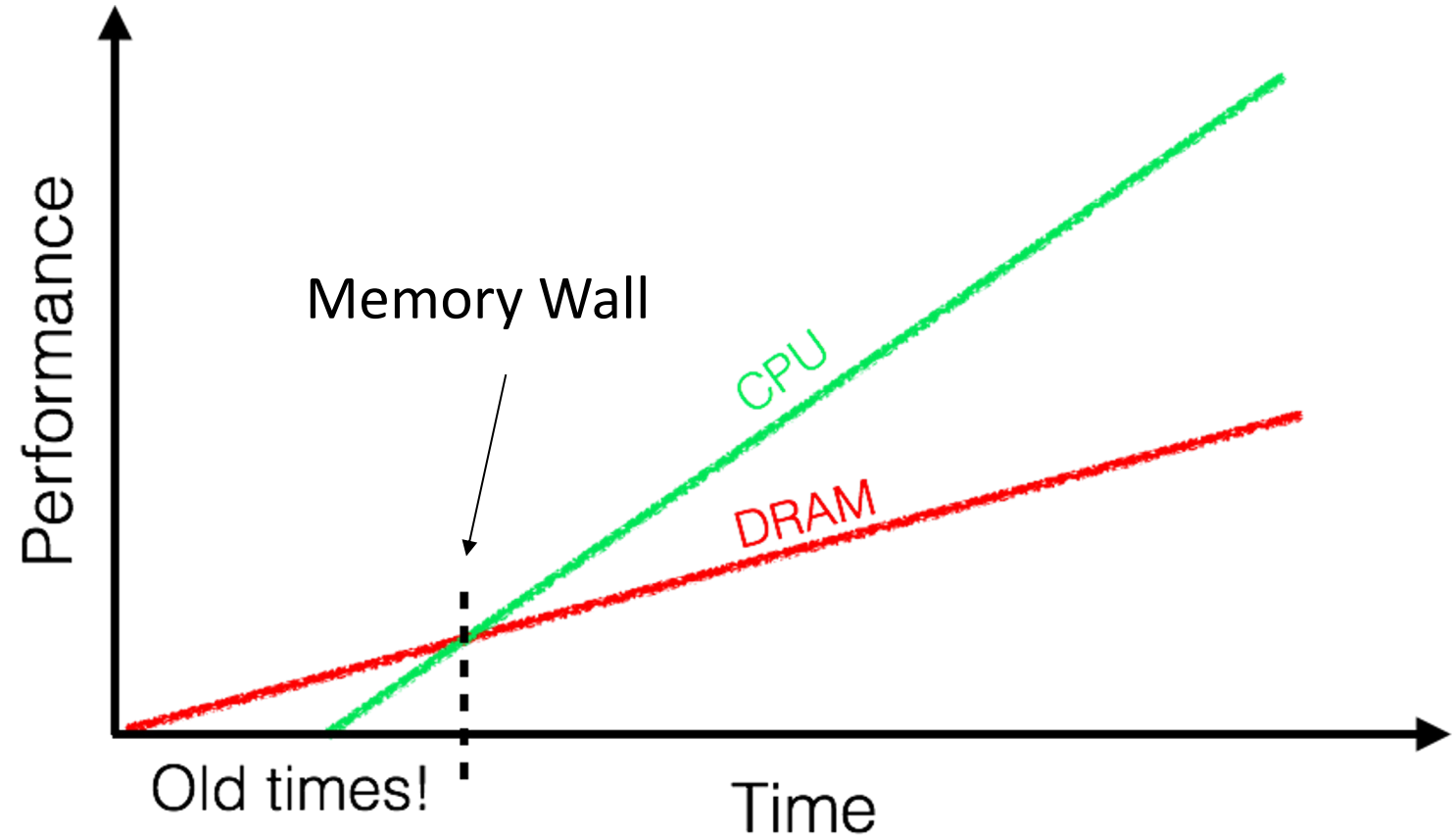

As the gap grows, we need a *deep memory hierarchy*

A single level of main memory is not enough

We need a *memory hierarchy*

What is the memory hierarchy ?

A bit of Class Logistics Before That...

- (Project) Mid-Semester Report due on ~~Mar 22~~ **Mar 29**
- Technical Questions 2, 3, 4, and 5 due on **Mar 25, 27, Apr 1 and 10**
- Review 4 due on **Apr 3**

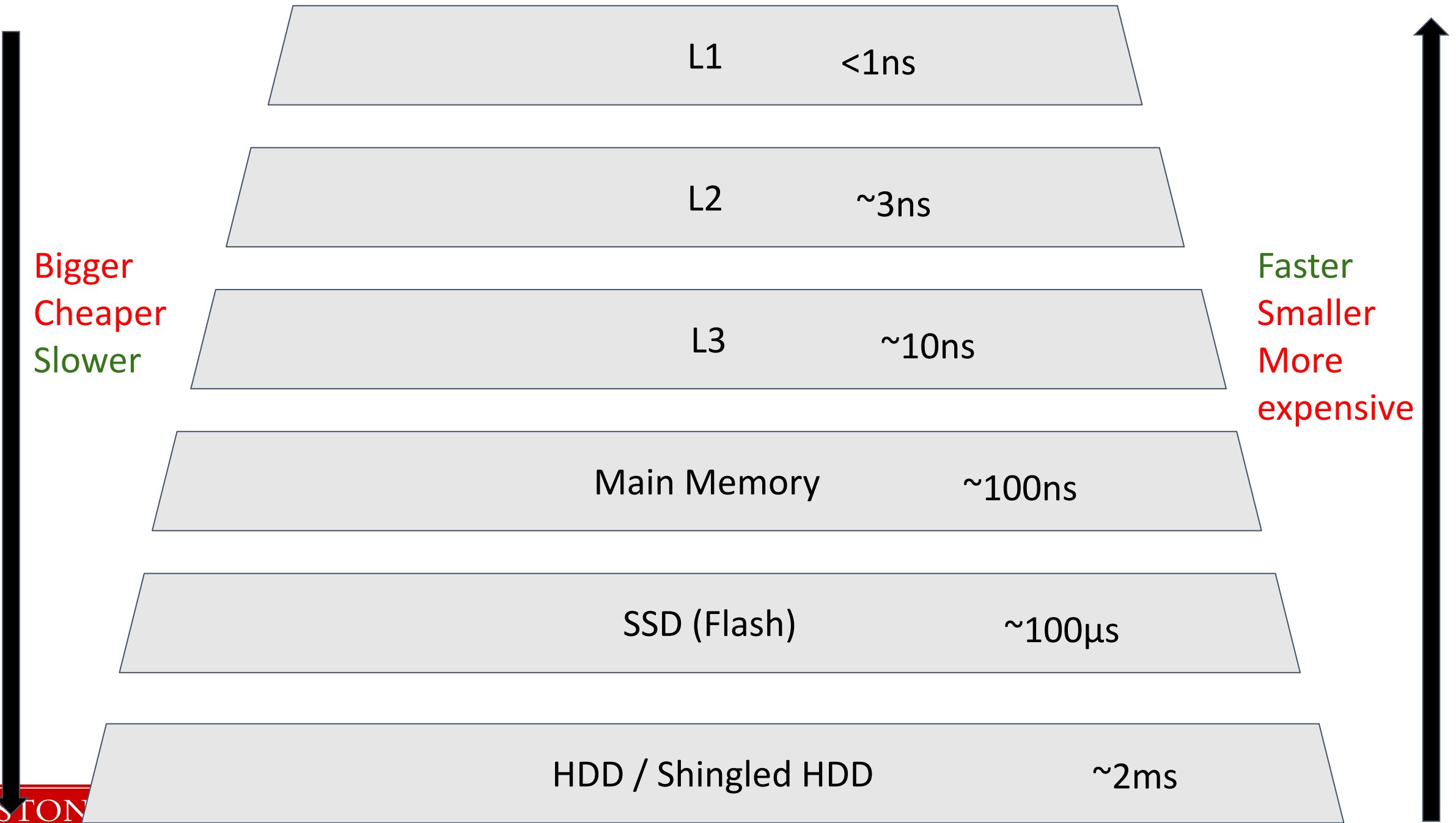

Bigger
Cheaper
Slower

Faster
Smaller
More expensive

Access Granularity

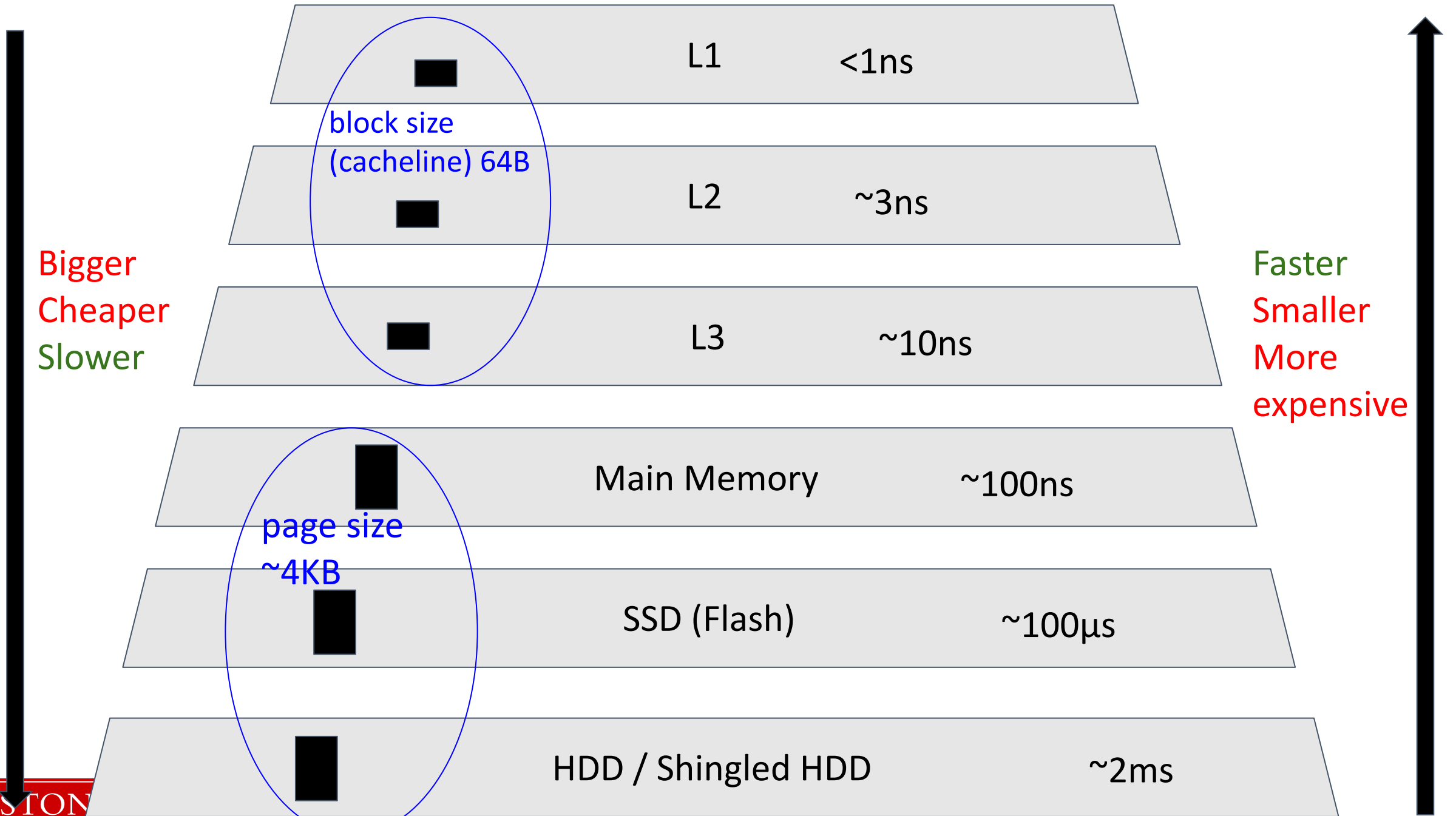

IO cost: Scanning a relation to select 10%

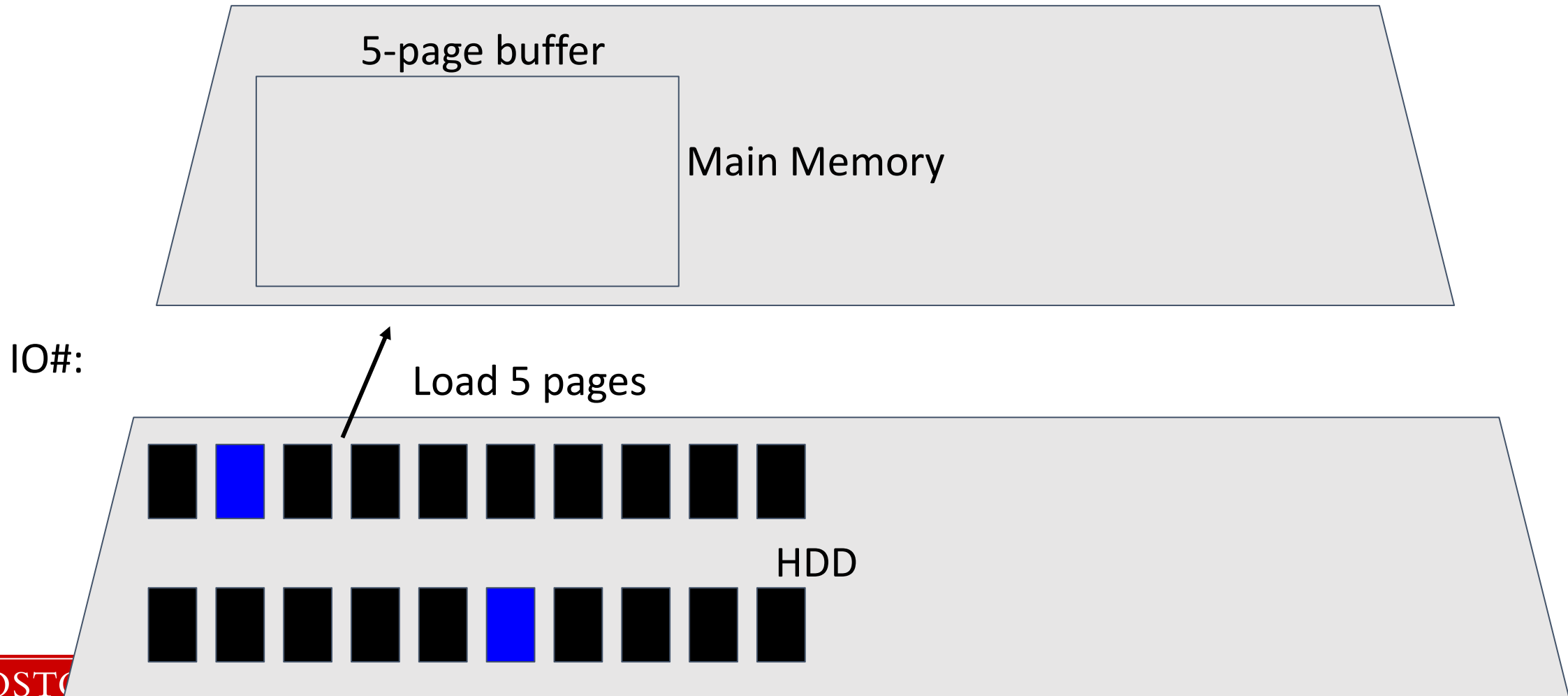

IO cost: Scanning a relation to select 10%

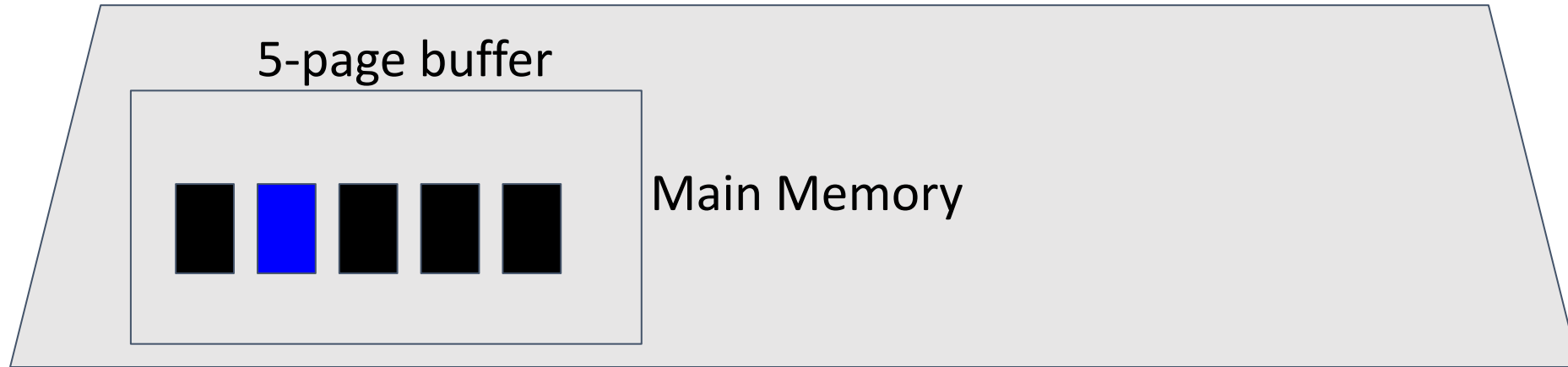

IO#: 5

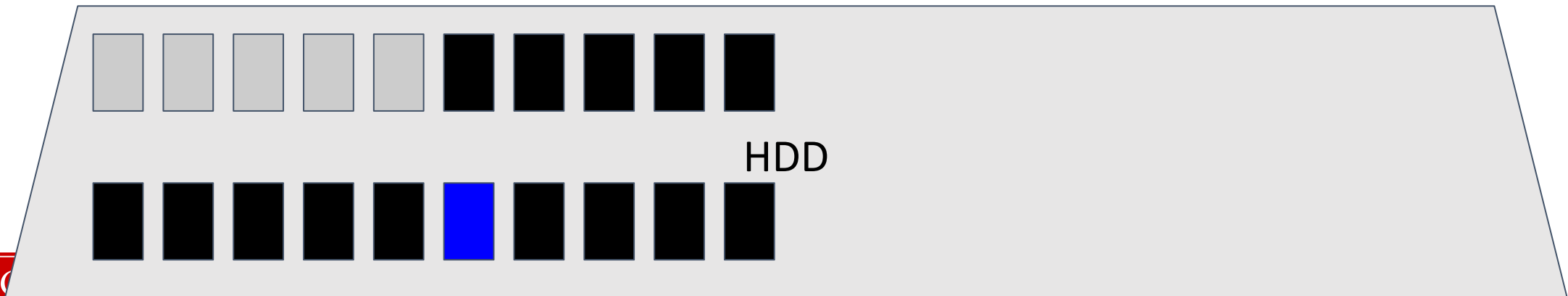

IO cost: Scanning a relation to select 10%

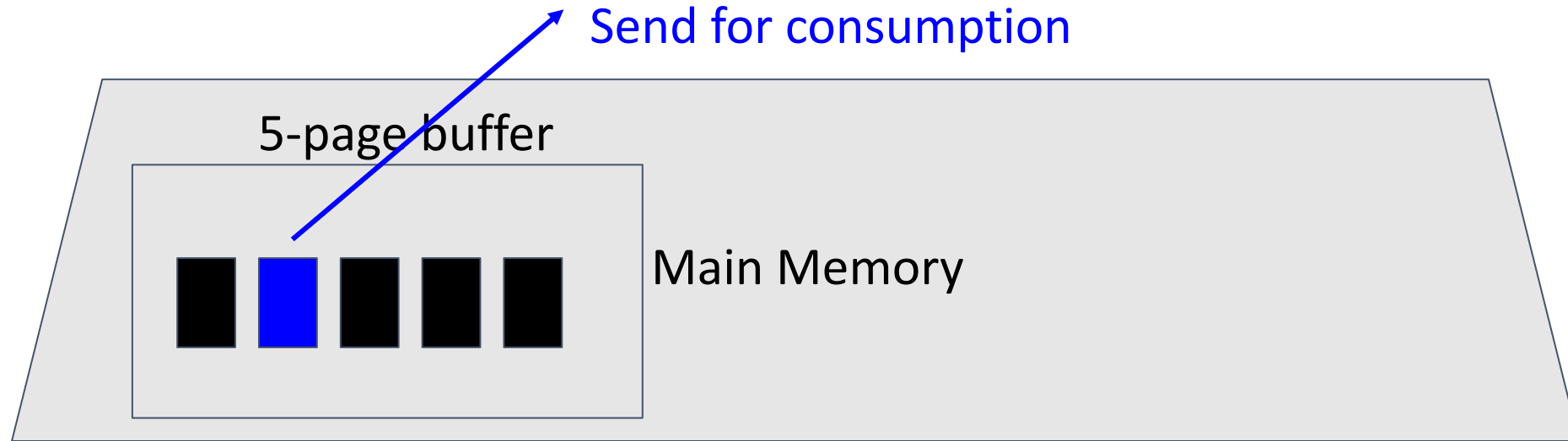

IO#: 5

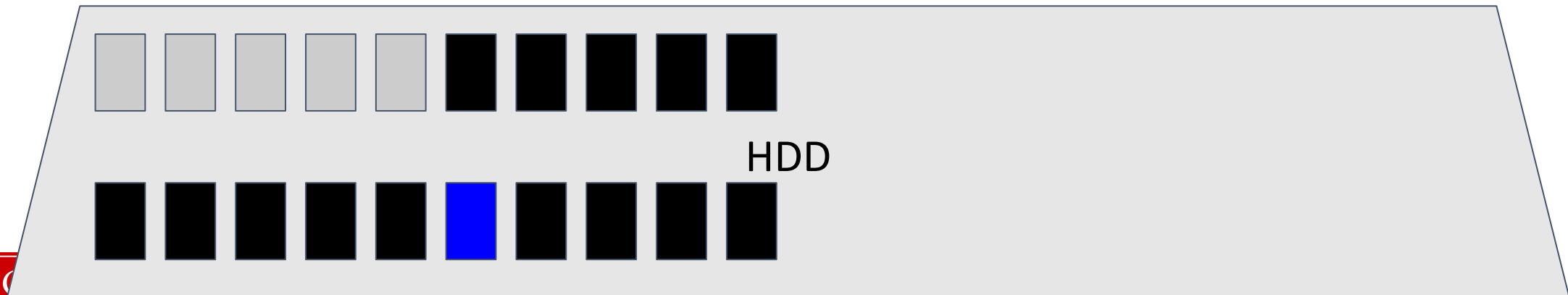

IO cost: Scanning a relation to select 10%

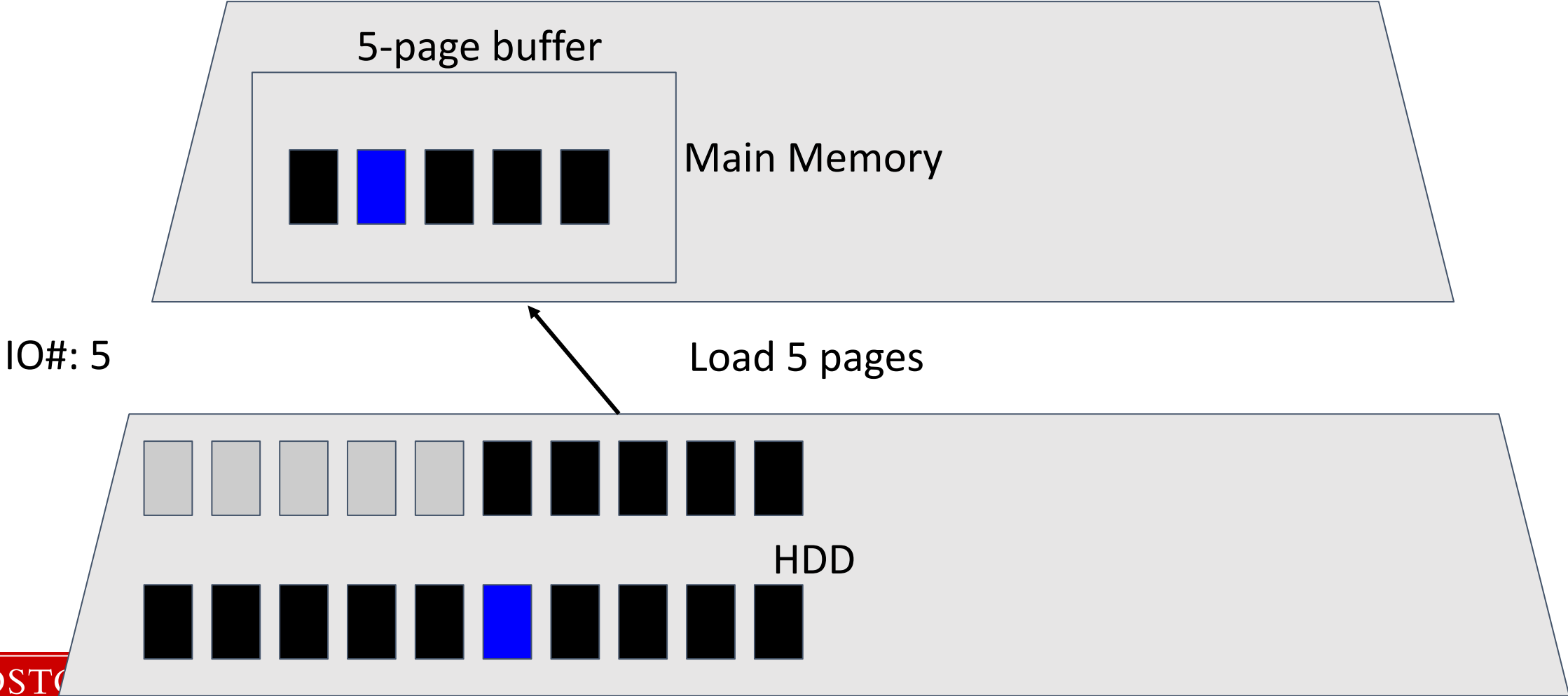

IO cost: Scanning a relation to select 10%

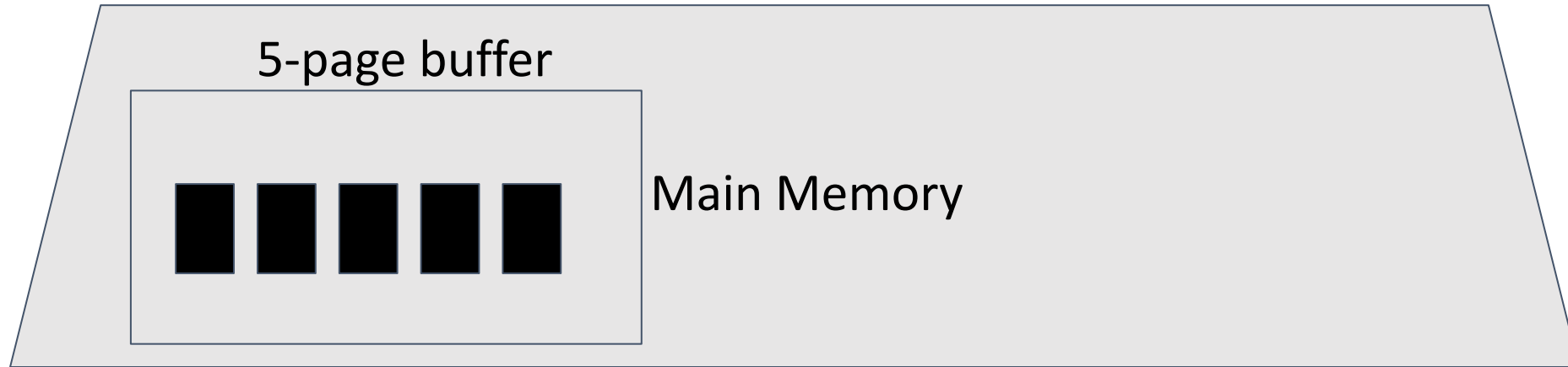

IO#: 10

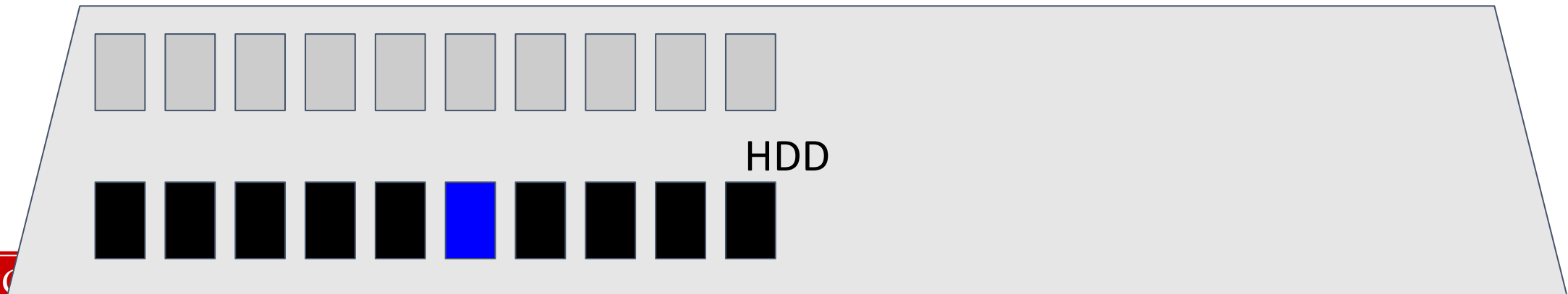

IO cost: Scanning a relation to select 10%

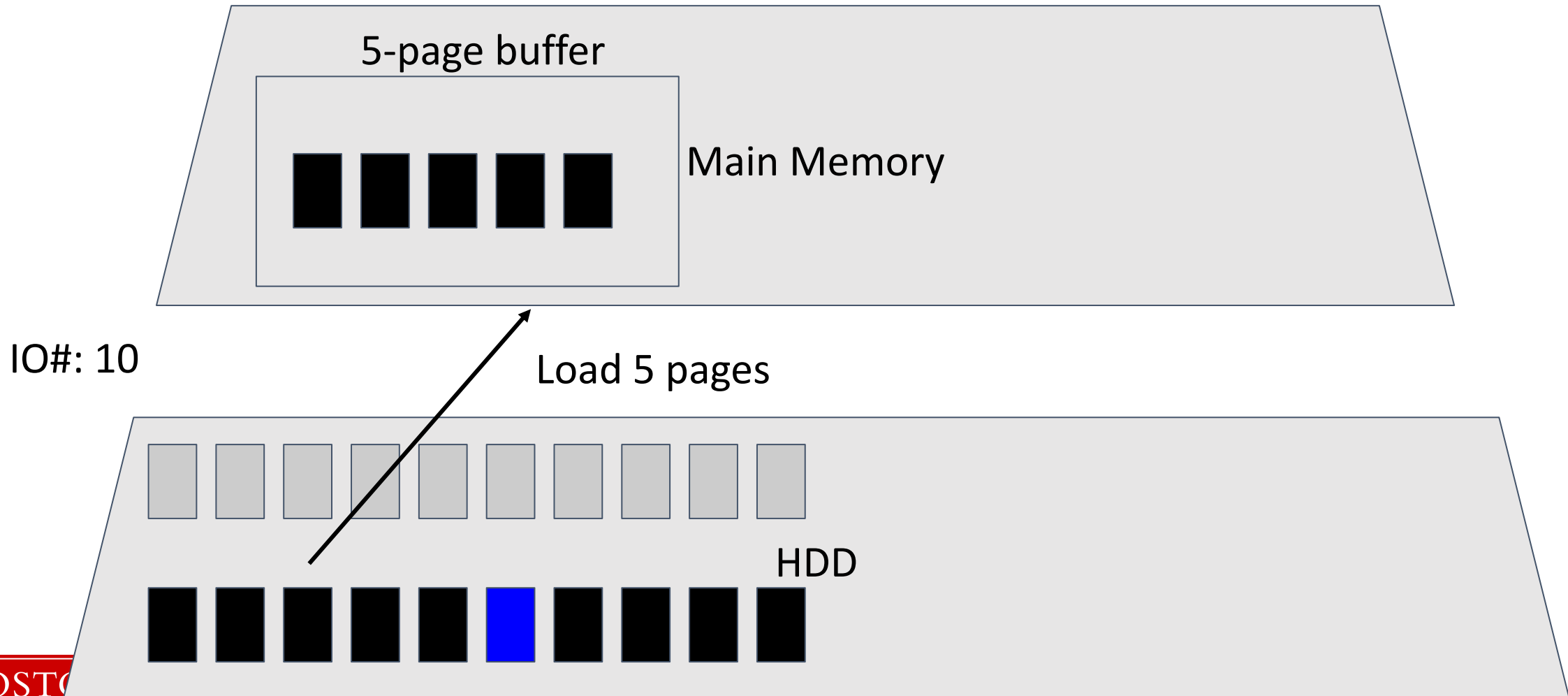

IO cost: Scanning a relation to select 10%

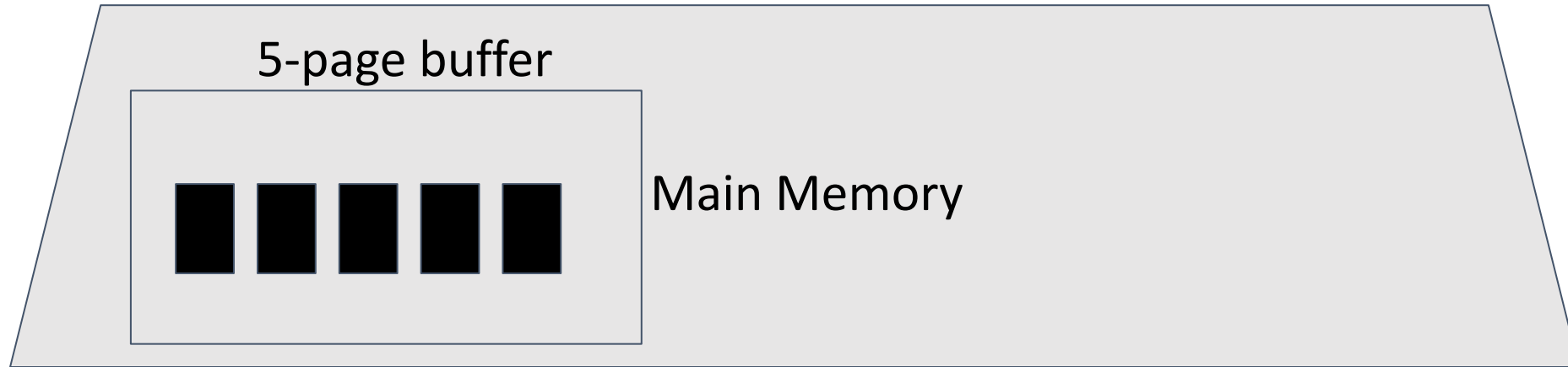

IO#: 15

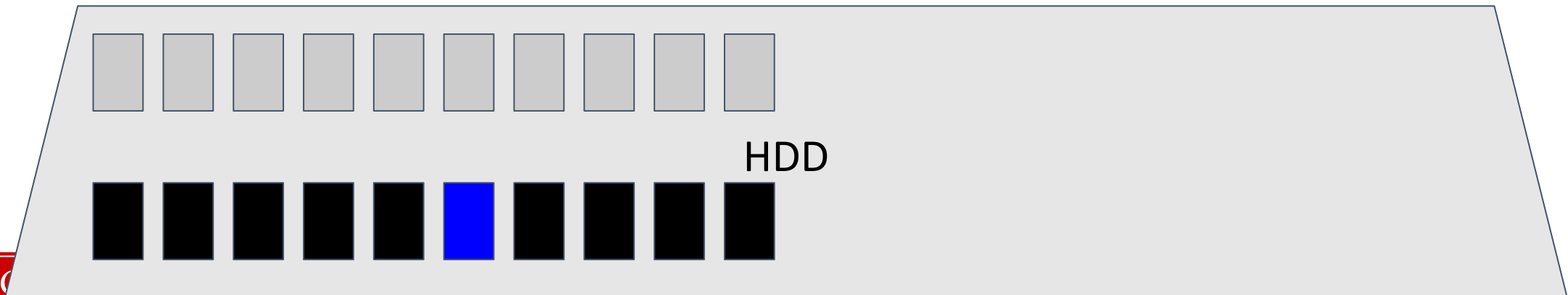

IO cost: Scanning a relation to select 10%

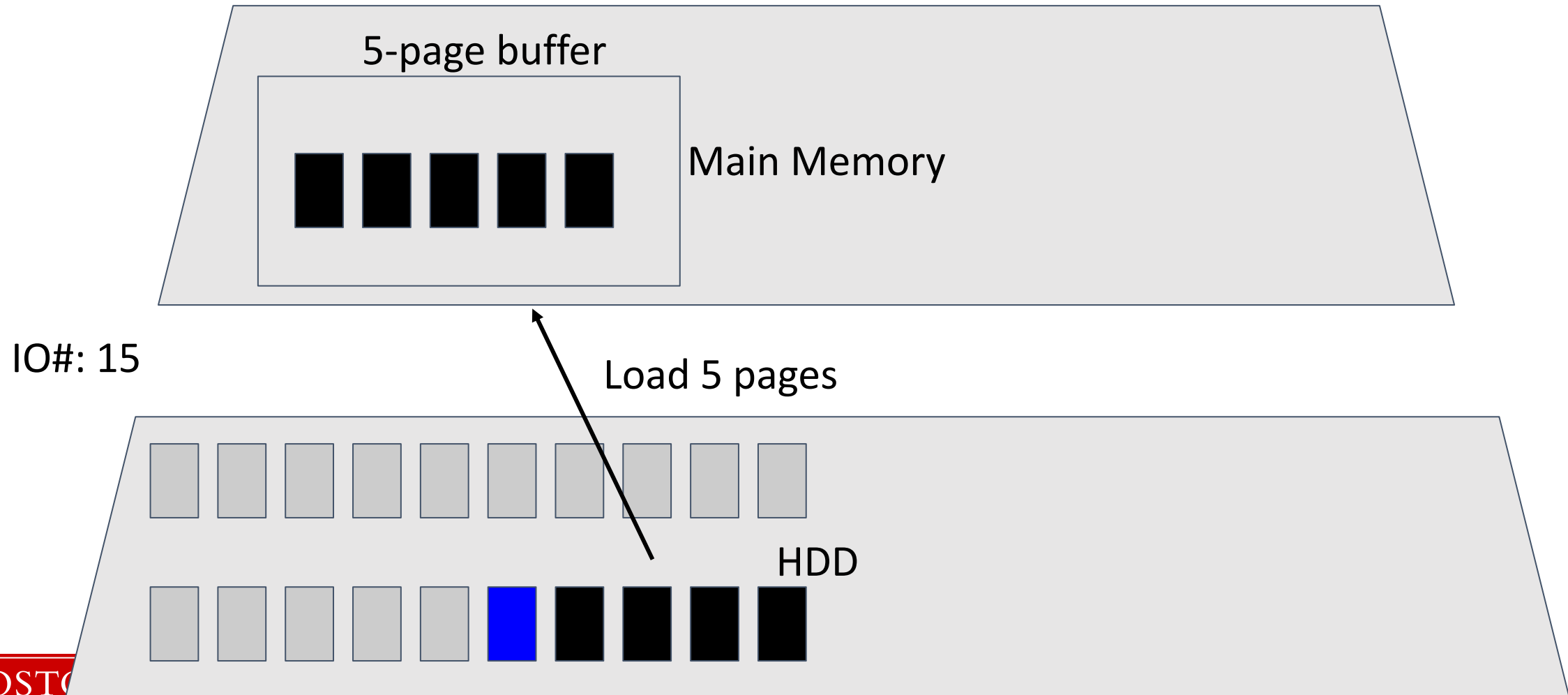

IO cost: Scanning a relation to select 10%

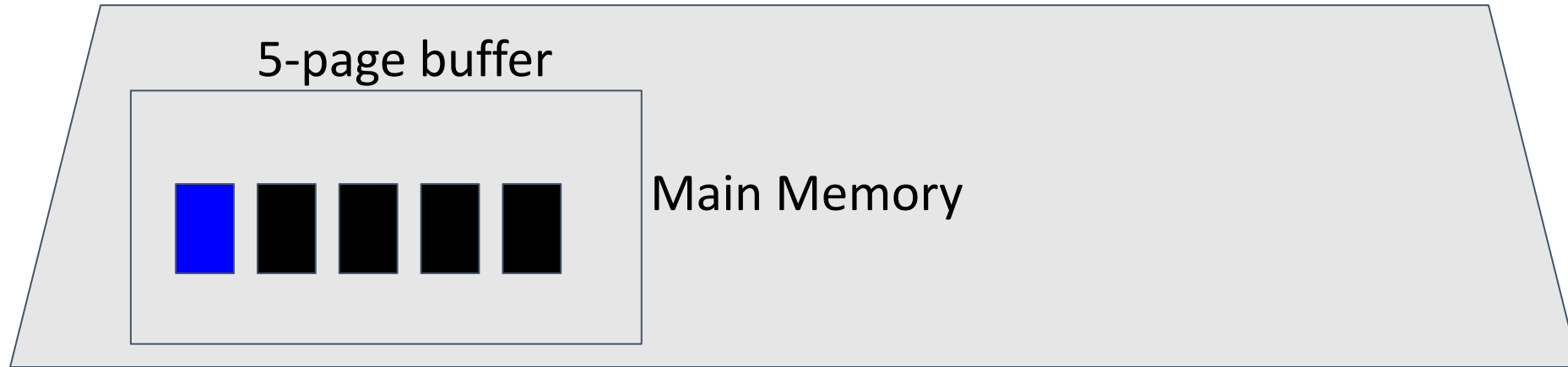

IO#:
20

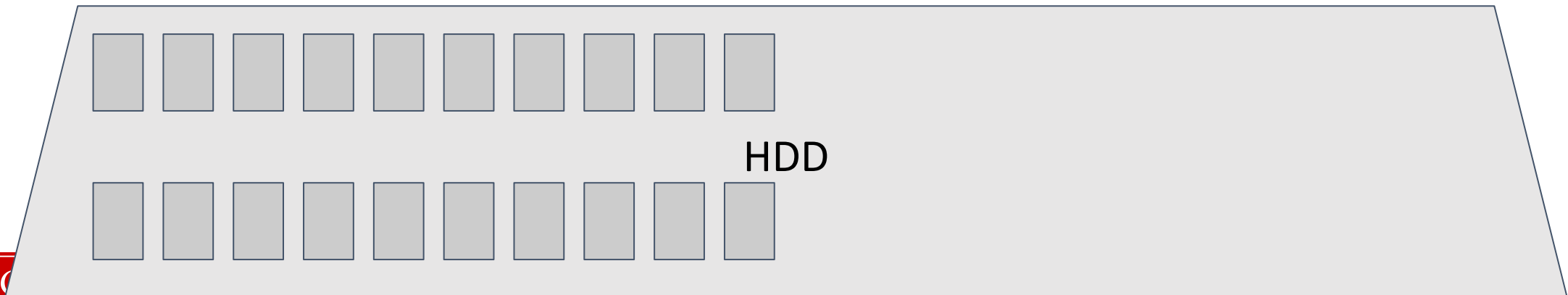

IO cost: Scanning a relation to select 10%

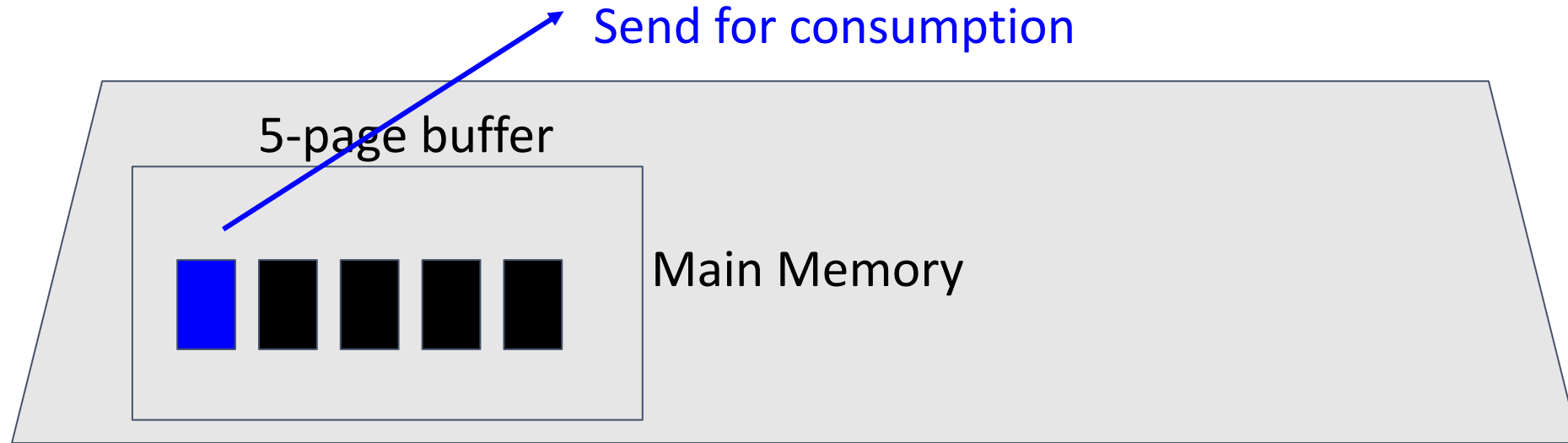

IO#:
20

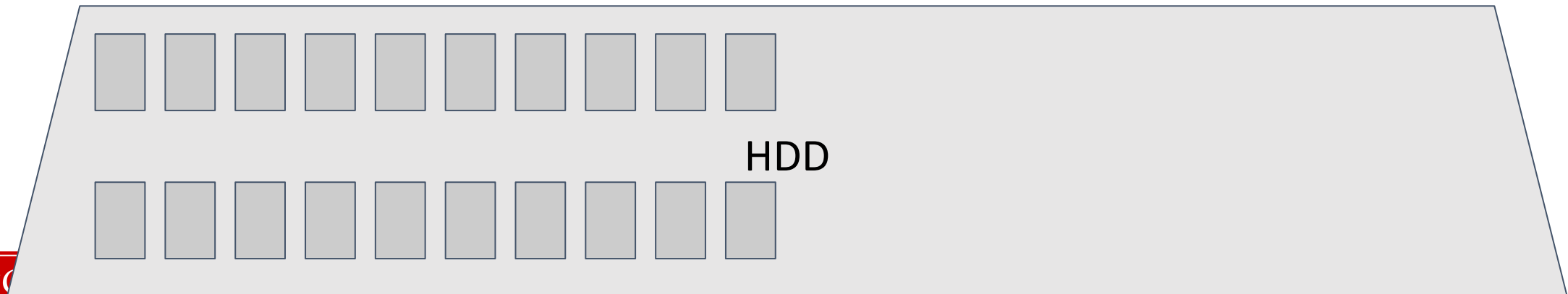

What if we had an oracle (index)?

IO cost: Scanning a relation to select 10%

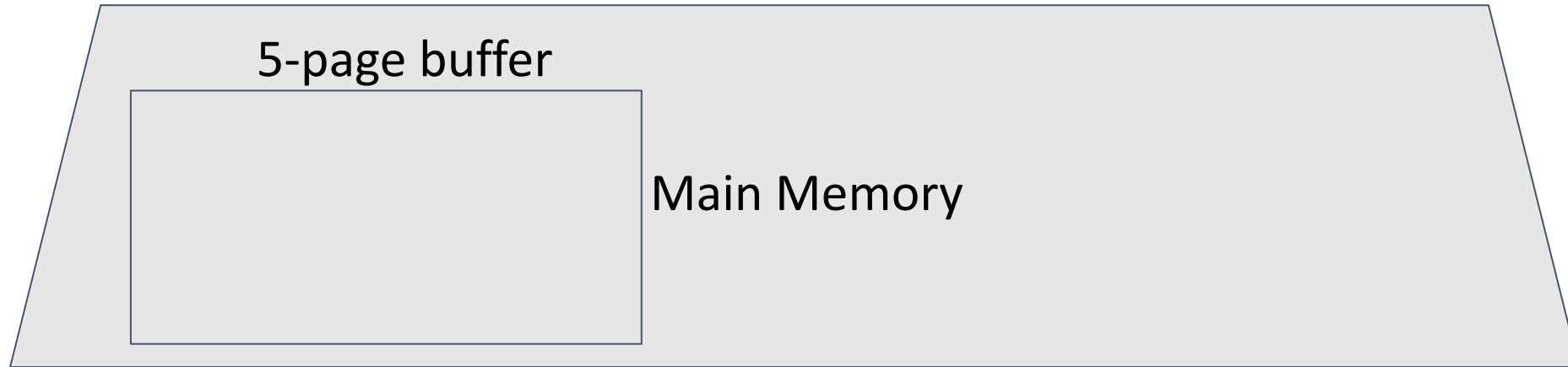

IO#:

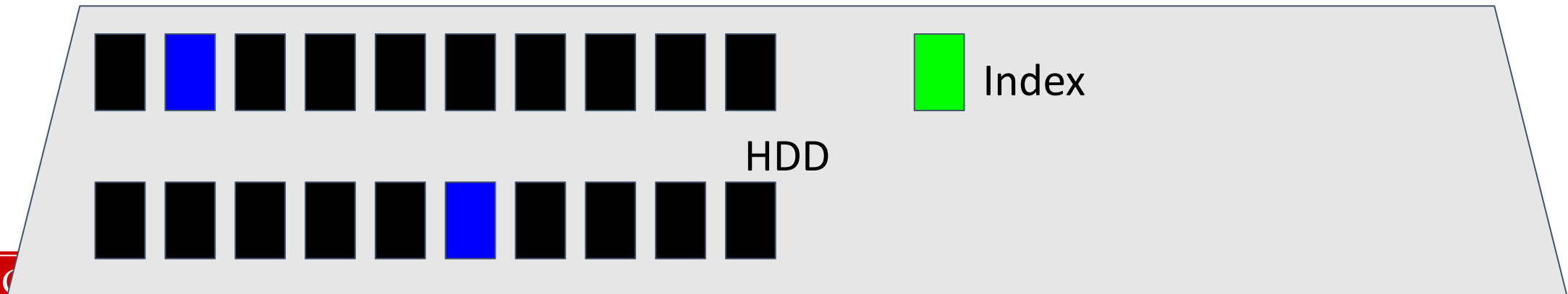

IO cost: Use an index to select 10%

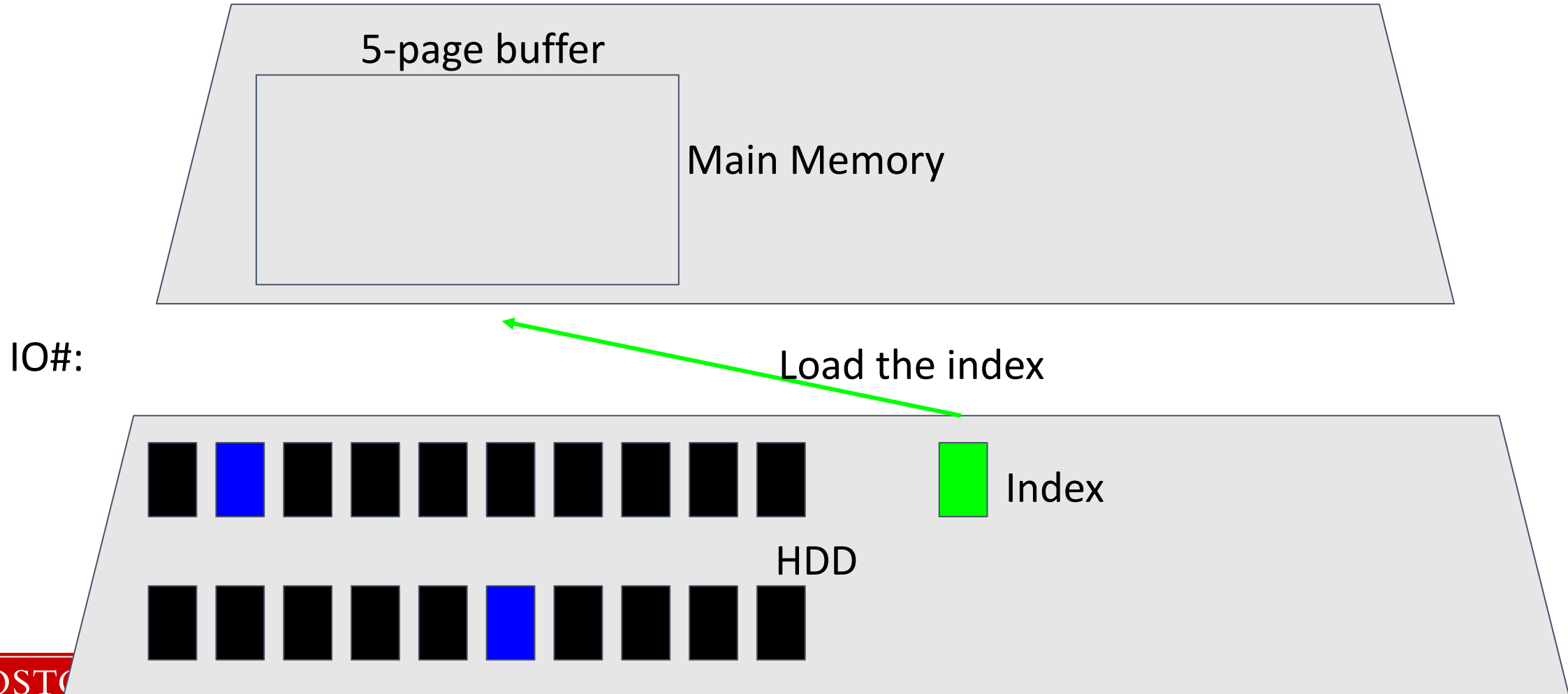

IO cost: Use an index to select 10%

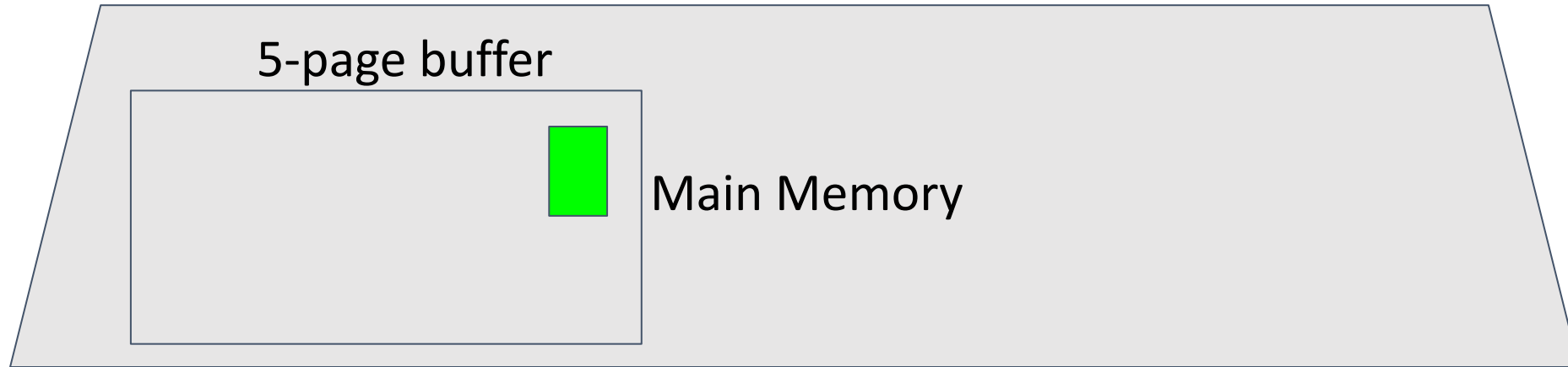

IO#: 1

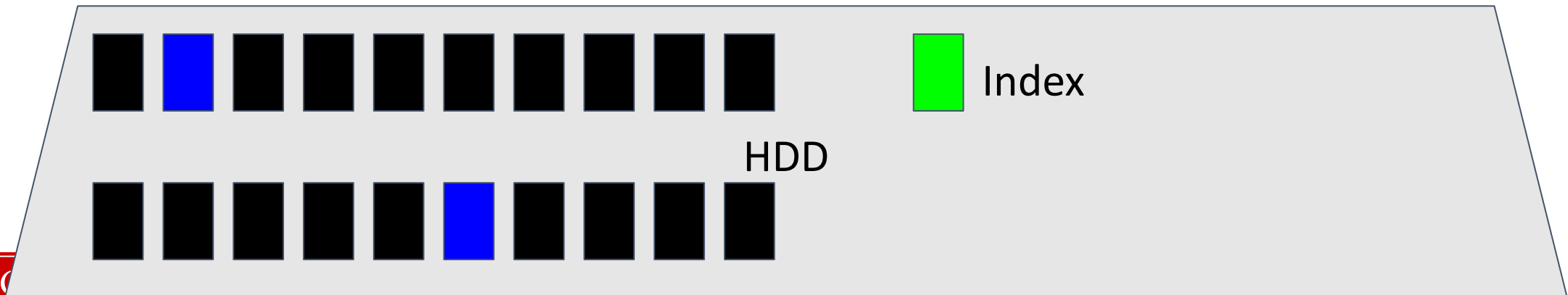

IO cost: Use an index to select 10%

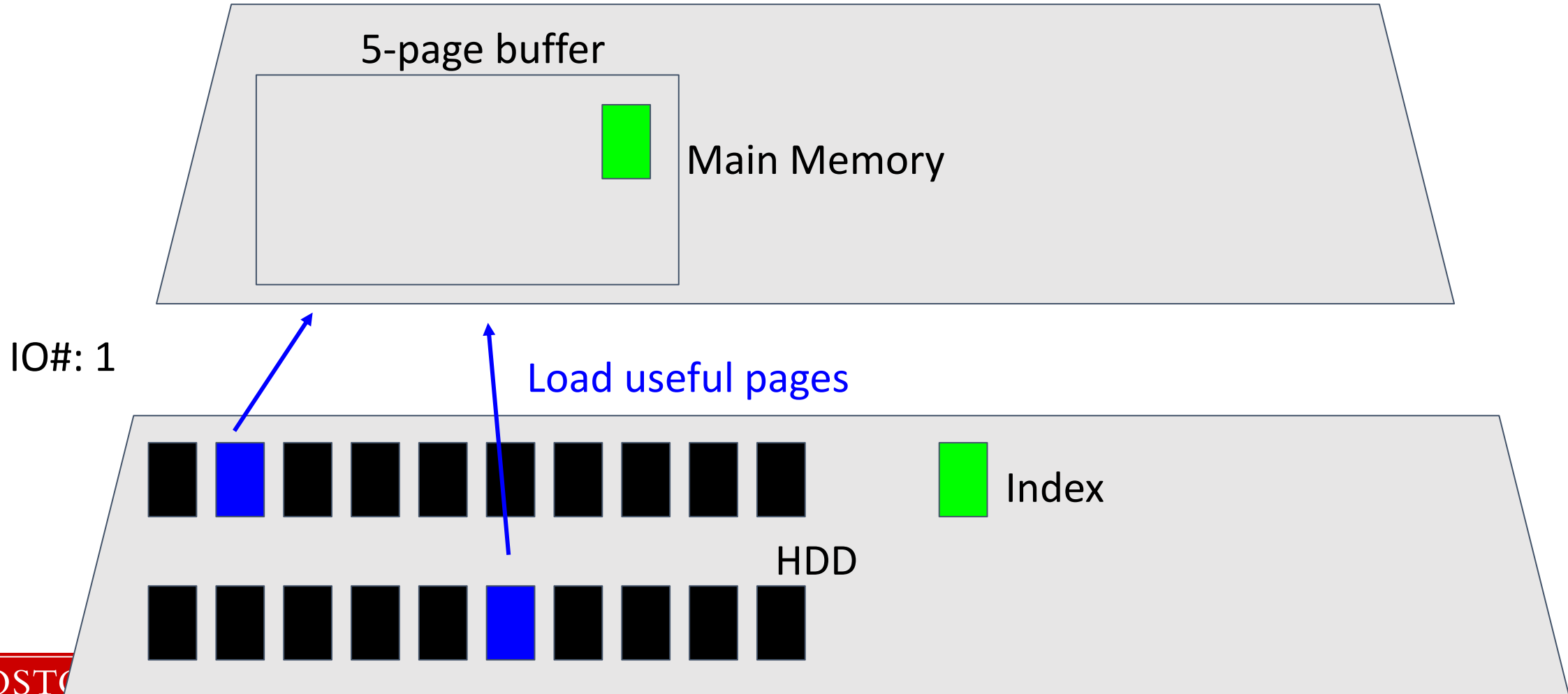

IO cost: Use an index to select 10%

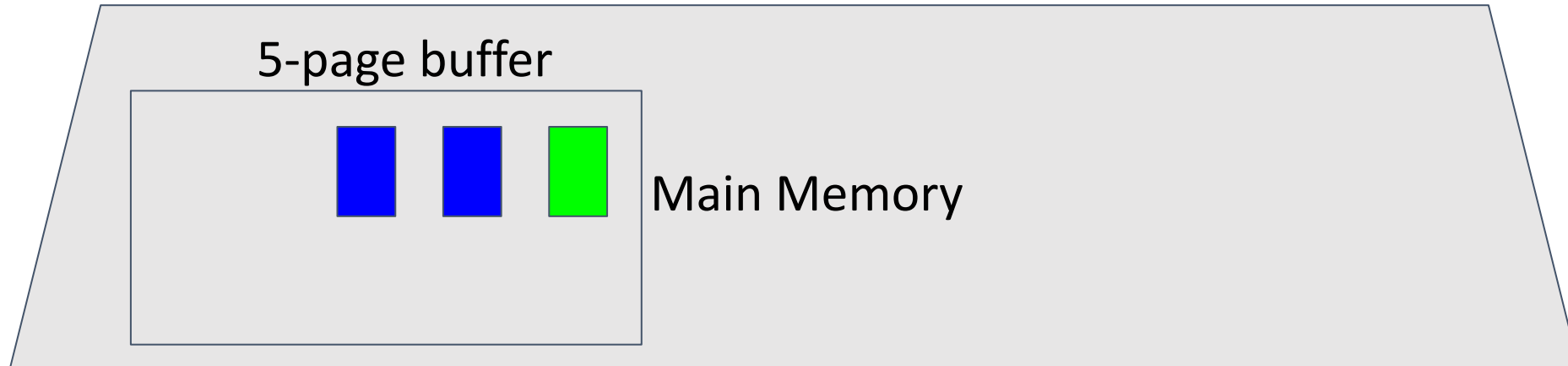

IO#: 3

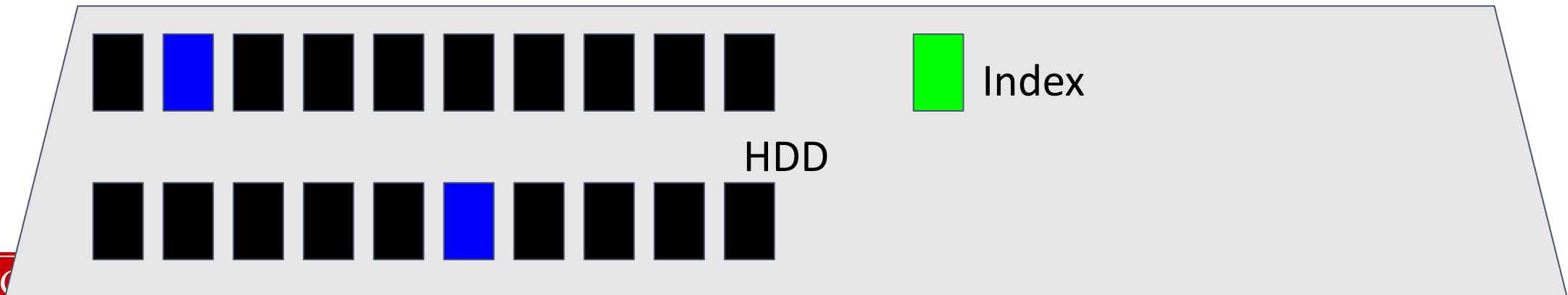

What if useful data is in all pages?

Scan or Index ?

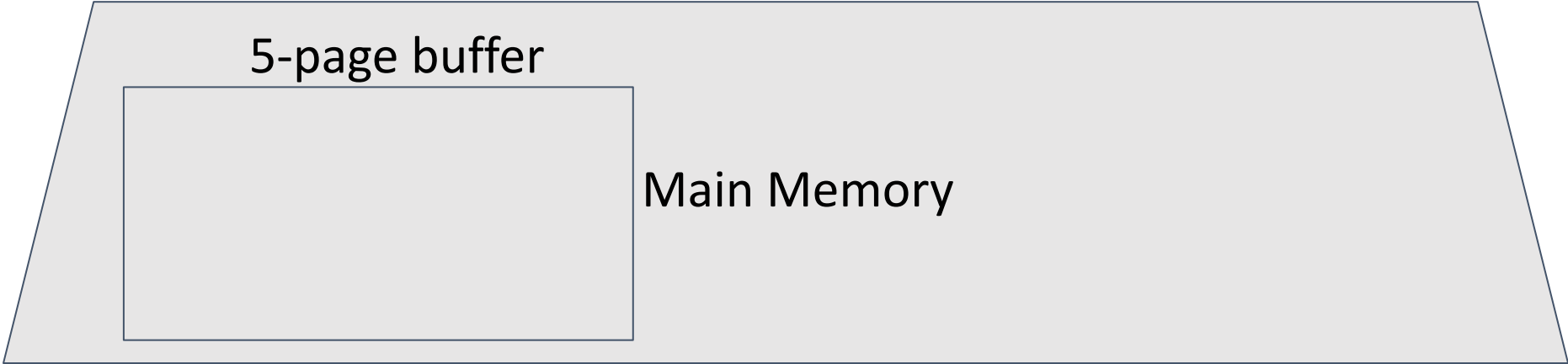

IO#:

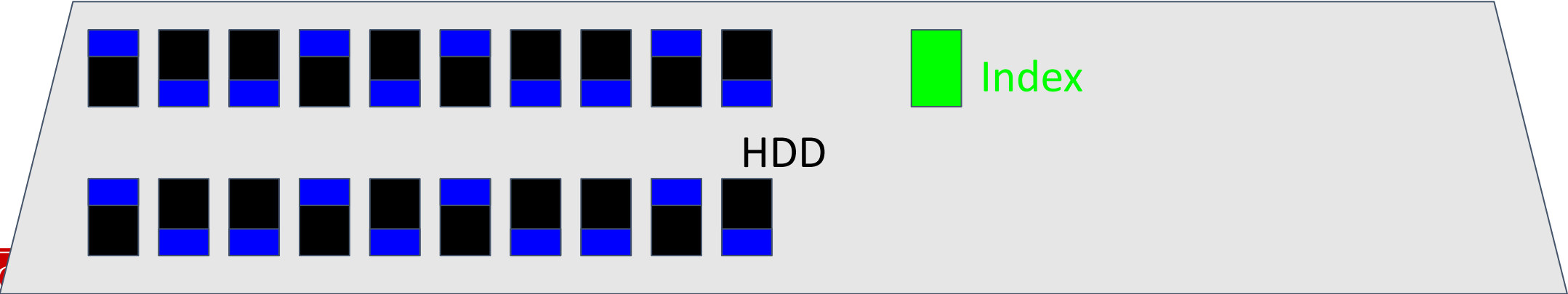

Scan or Index ?

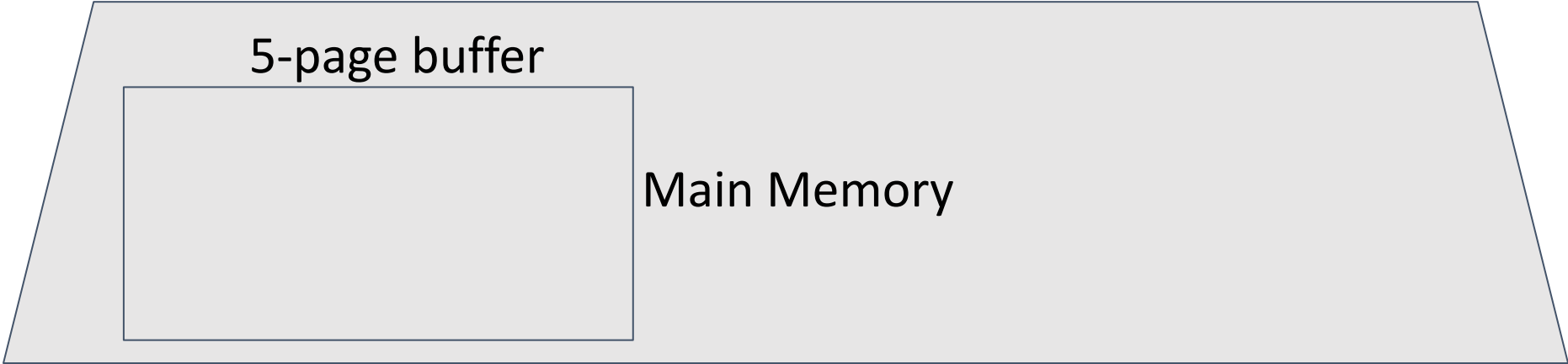

IO#: 20 with scan

IO#: 21 with index

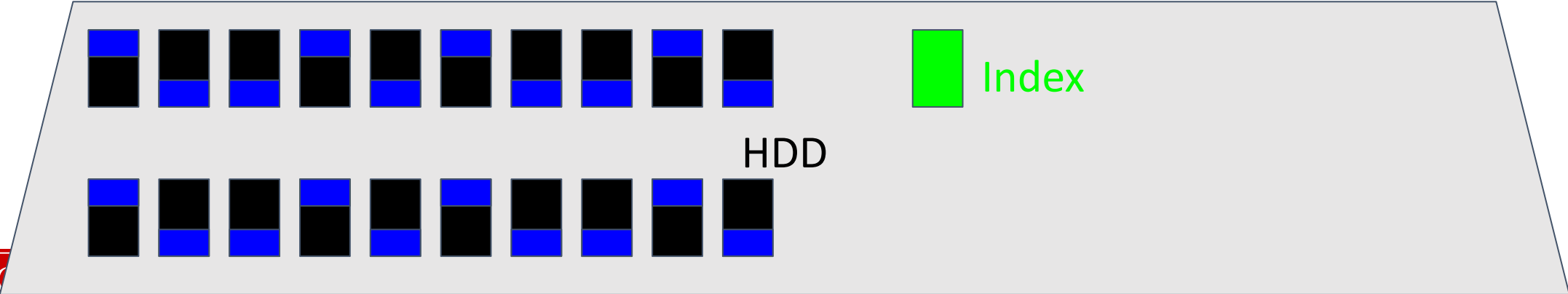

Same analysis for any two memory levels!!

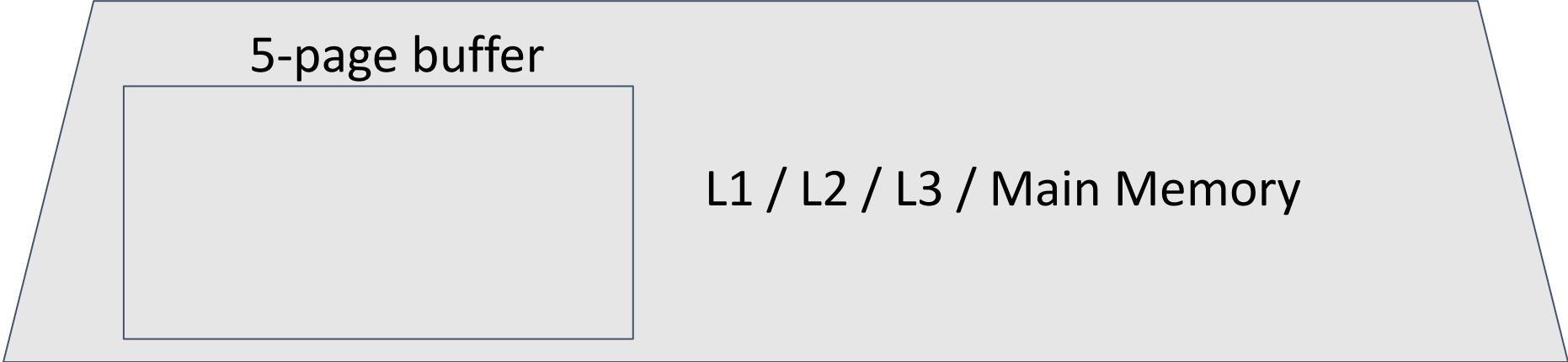

IO#:

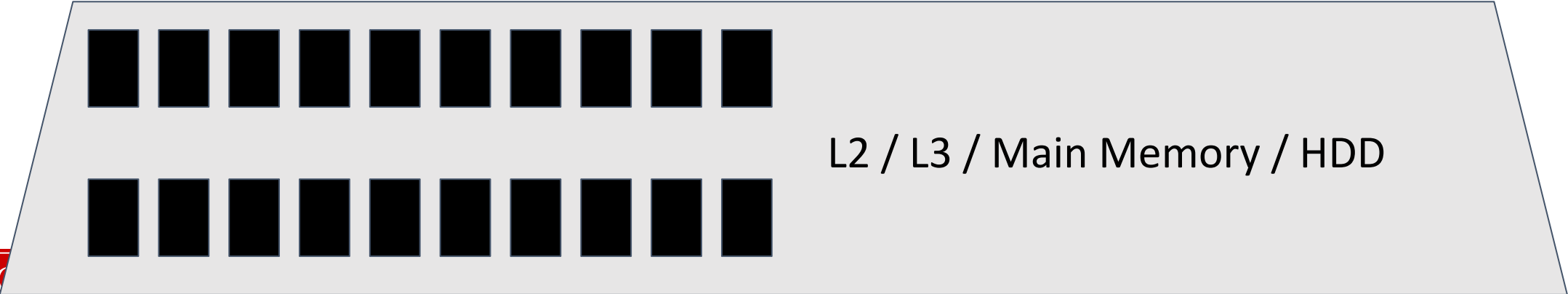

Cache Hierarchy

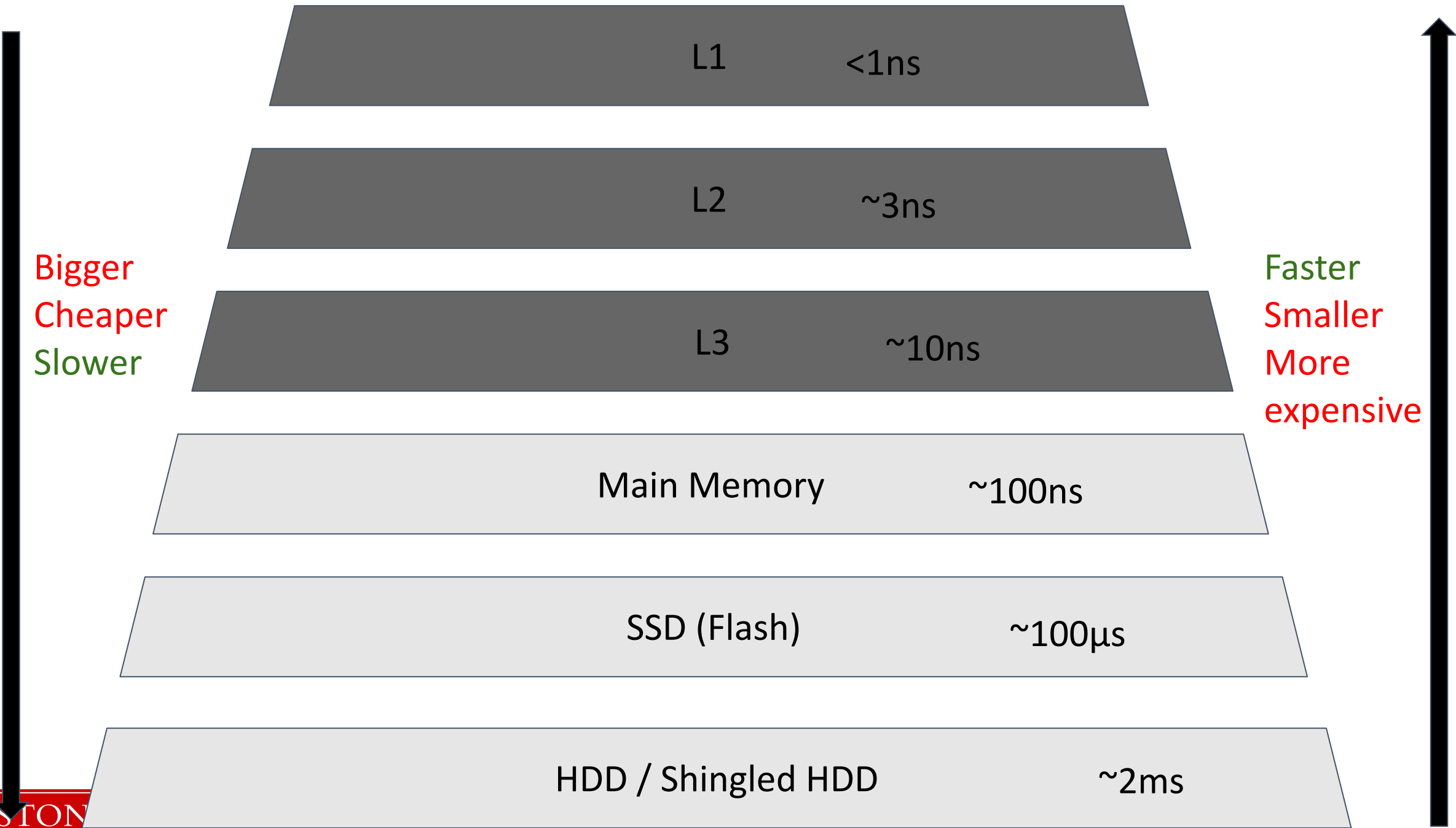

Bigger
Cheaper
Slower

Faster
Smaller
More expensive

Cache Hierarchy

What is a core?

What is a socket?

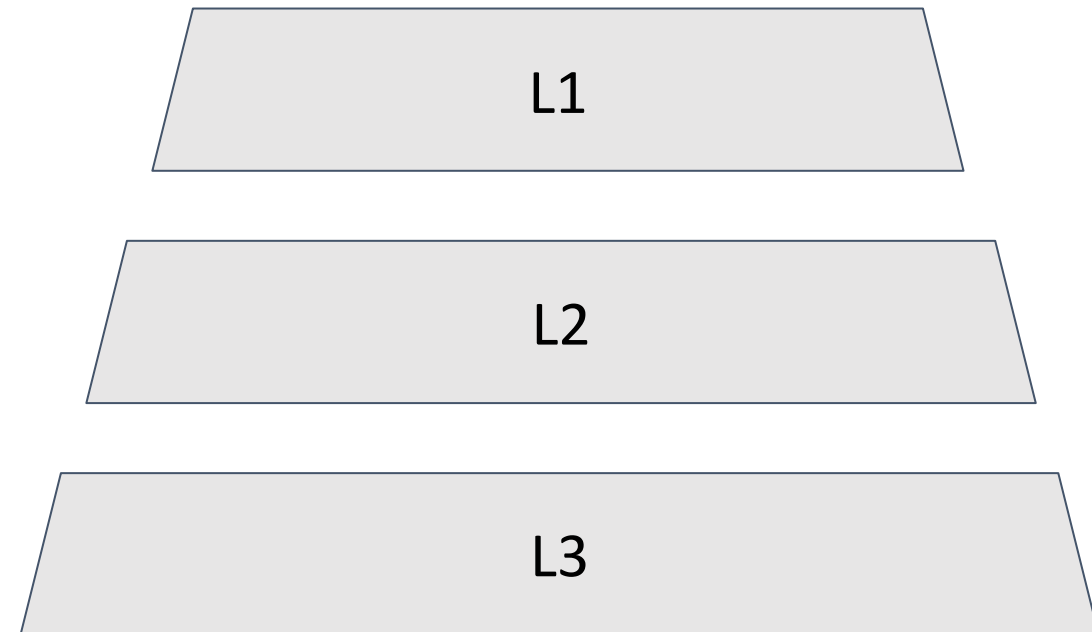
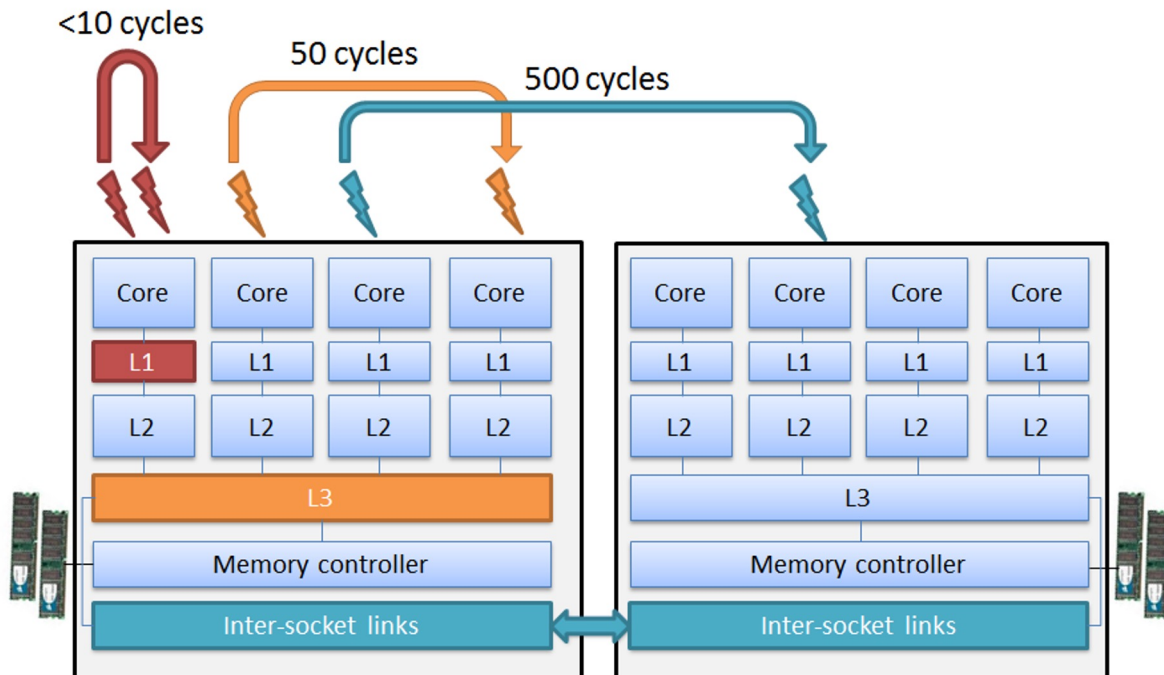

Cache Hierarchy

Shared Cache: L3 (or LLC: Last Level Cache)

L3 is physically distributed in multiple sockets

L2 is physically distributed in every core of every socket

Each *core* has its own **private** L1 & L2 cache

All levels need to be ***coherent****

what does coherent mean?

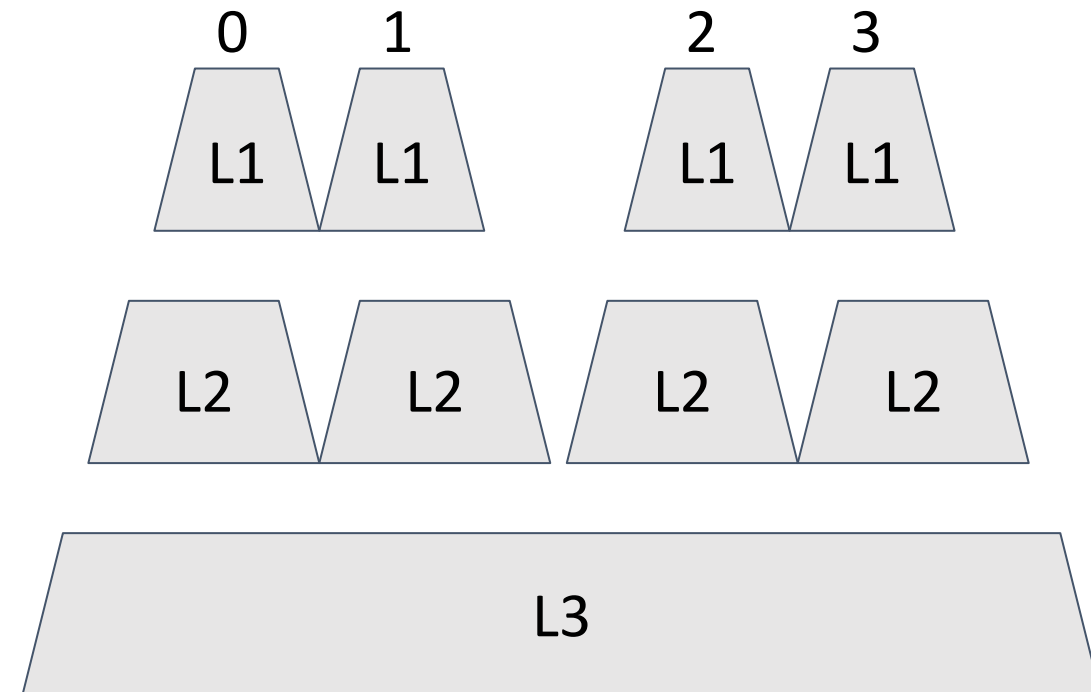

Non Uniform Memory Access (NUMA)

A core reads faster when data are in its L1

If it does not fit, it will go to L2, and then in L3

Can we control where data is placed?

We would like to avoid going to L2 and L3 altogether

But, at least we want to avoid to remote L2 and L3

And remember: this is only one socket.

We have **multiple** sockets!

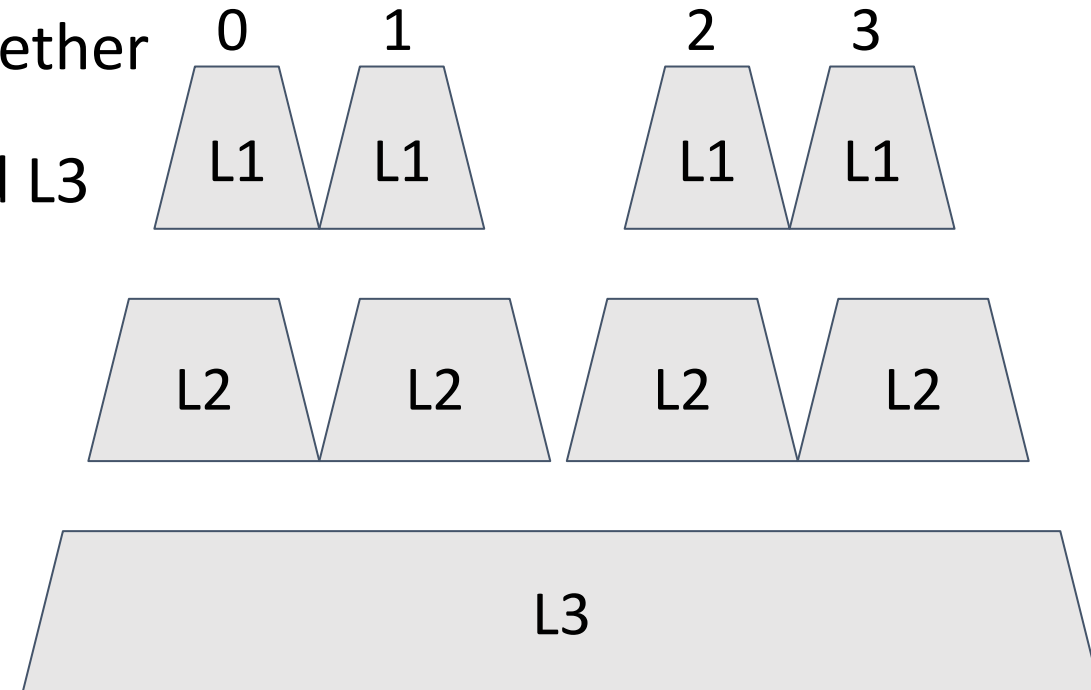

Non Uniform Memory Access (NUMA)

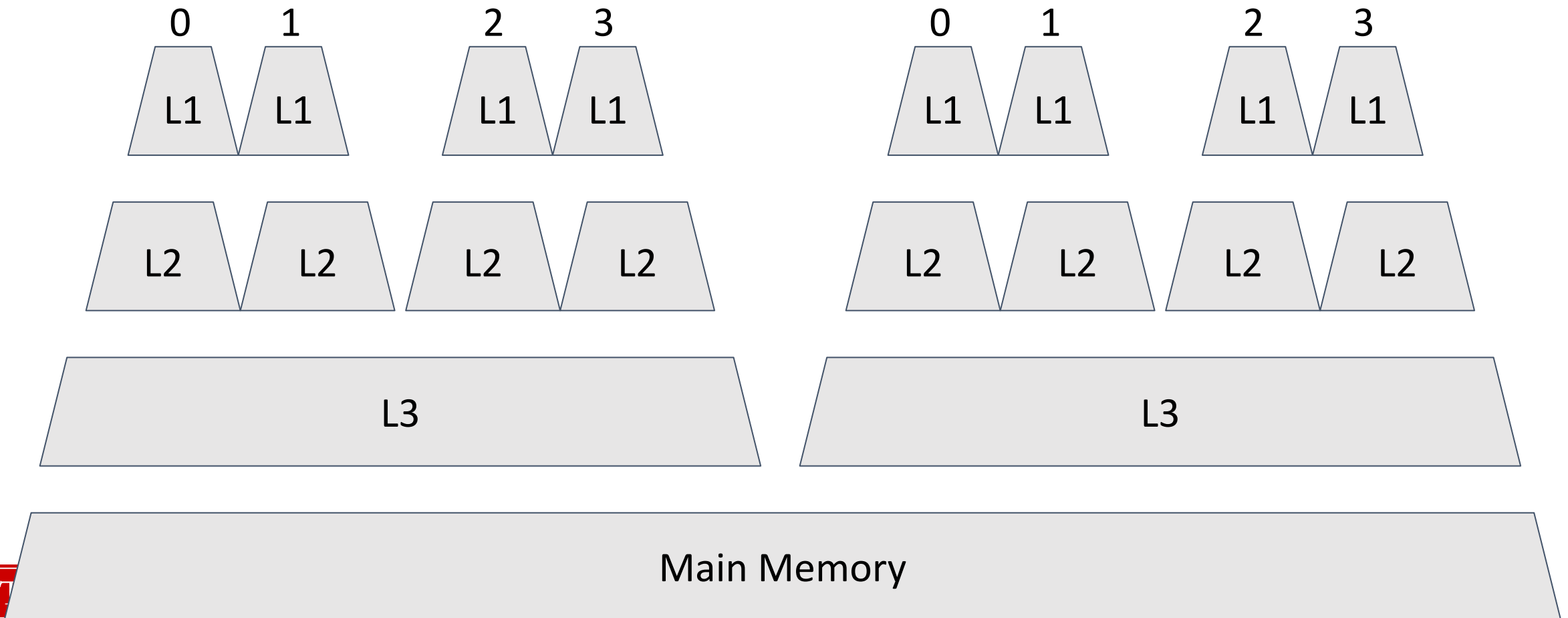

Non Uniform Memory Access (NUMA)

Cache hit!

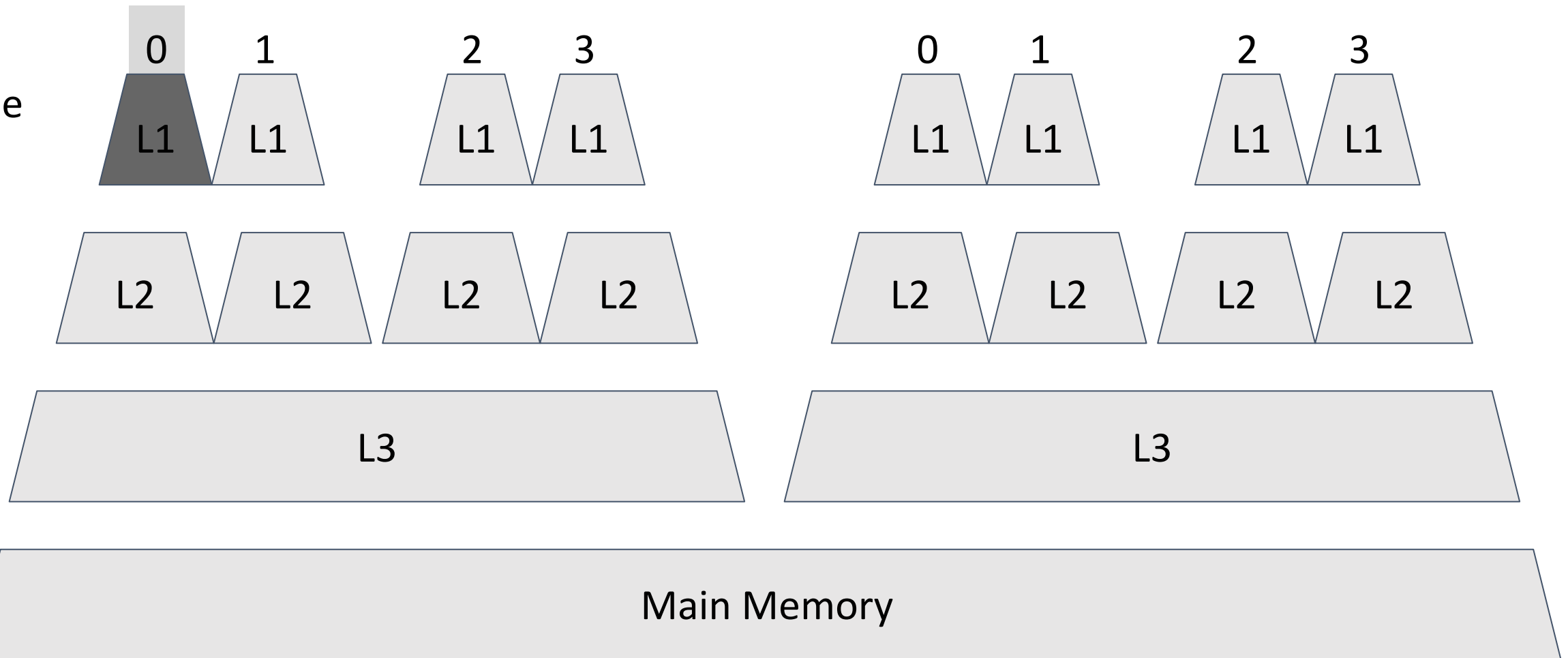

Non Uniform Memory Access (NUMA)

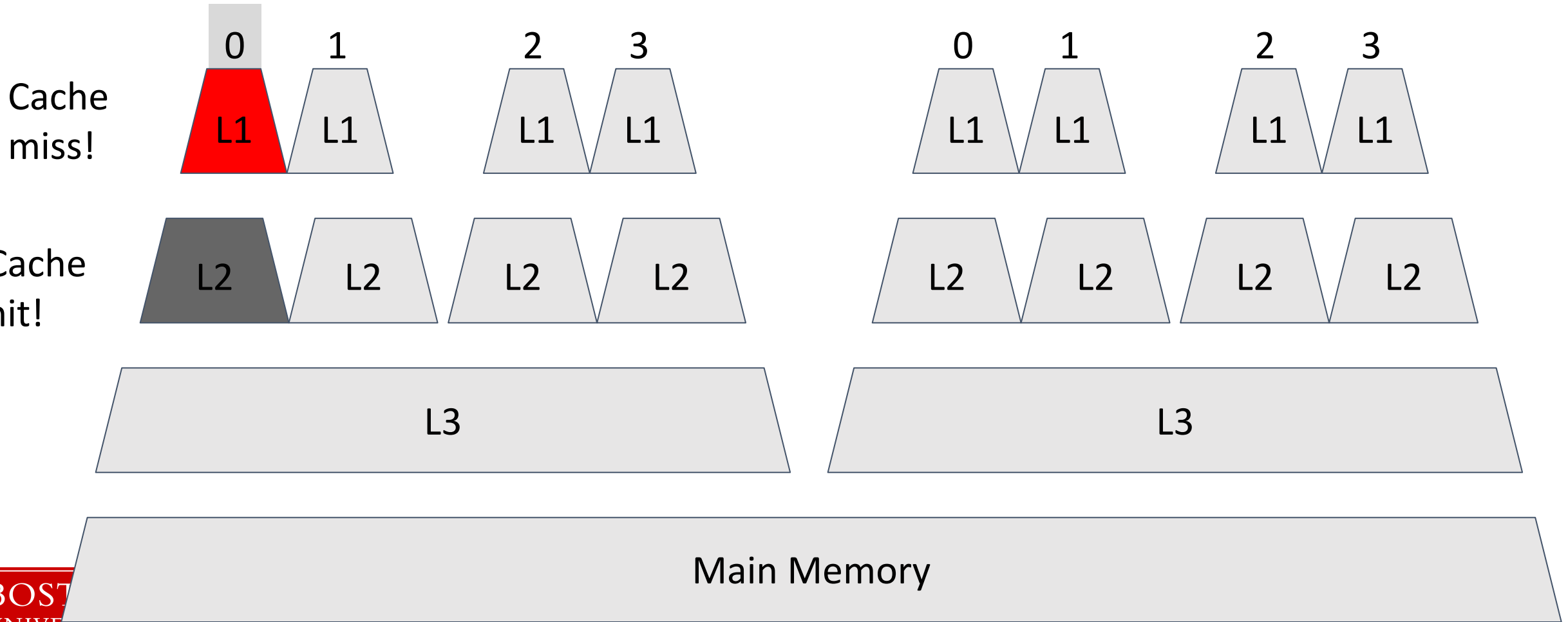

Non Uniform Memory Access (NUMA)

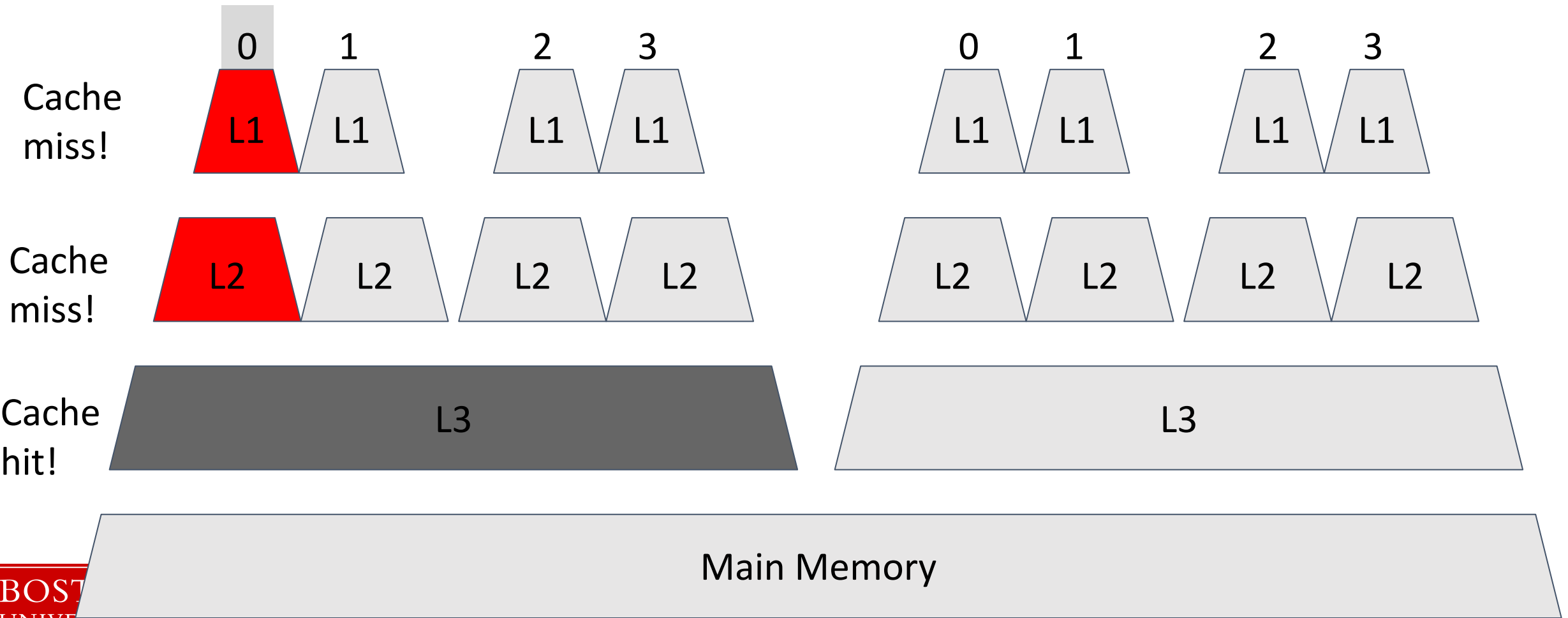

Non Uniform Memory Access (NUMA)

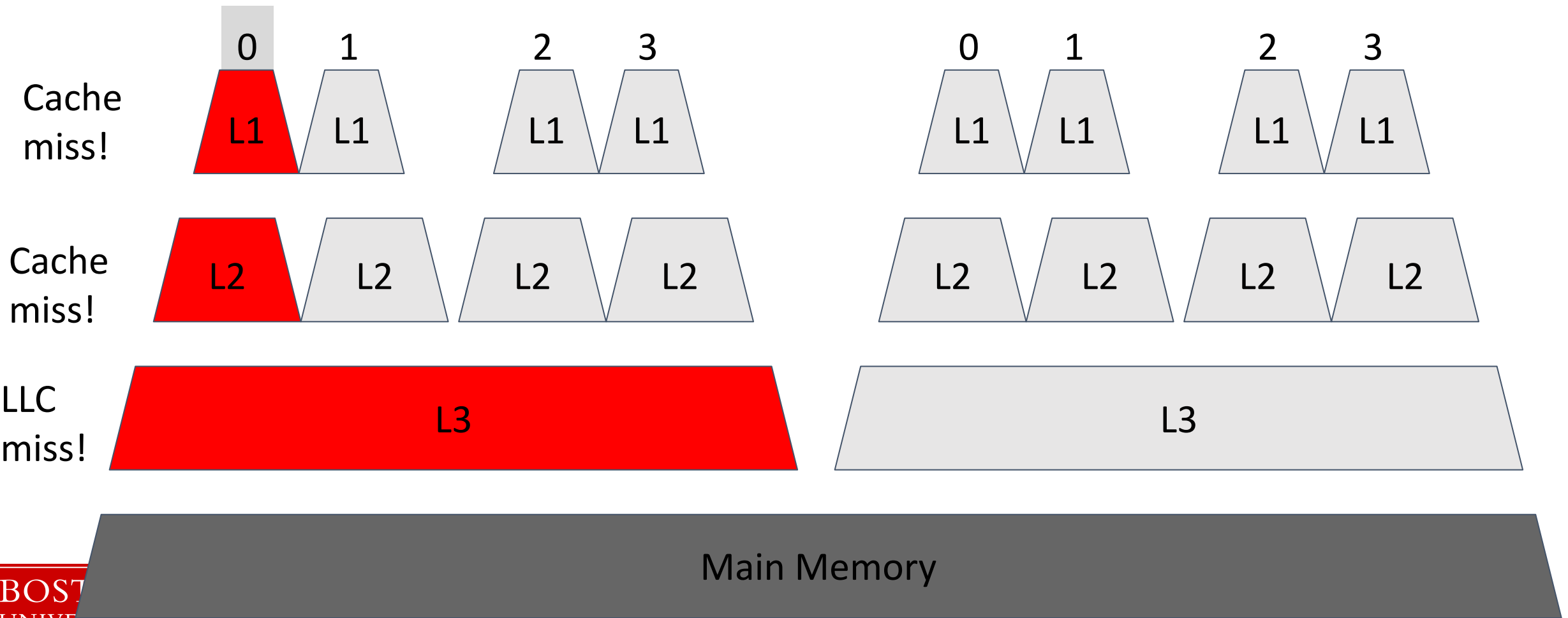

Non Uniform Memory Access (NUMA)

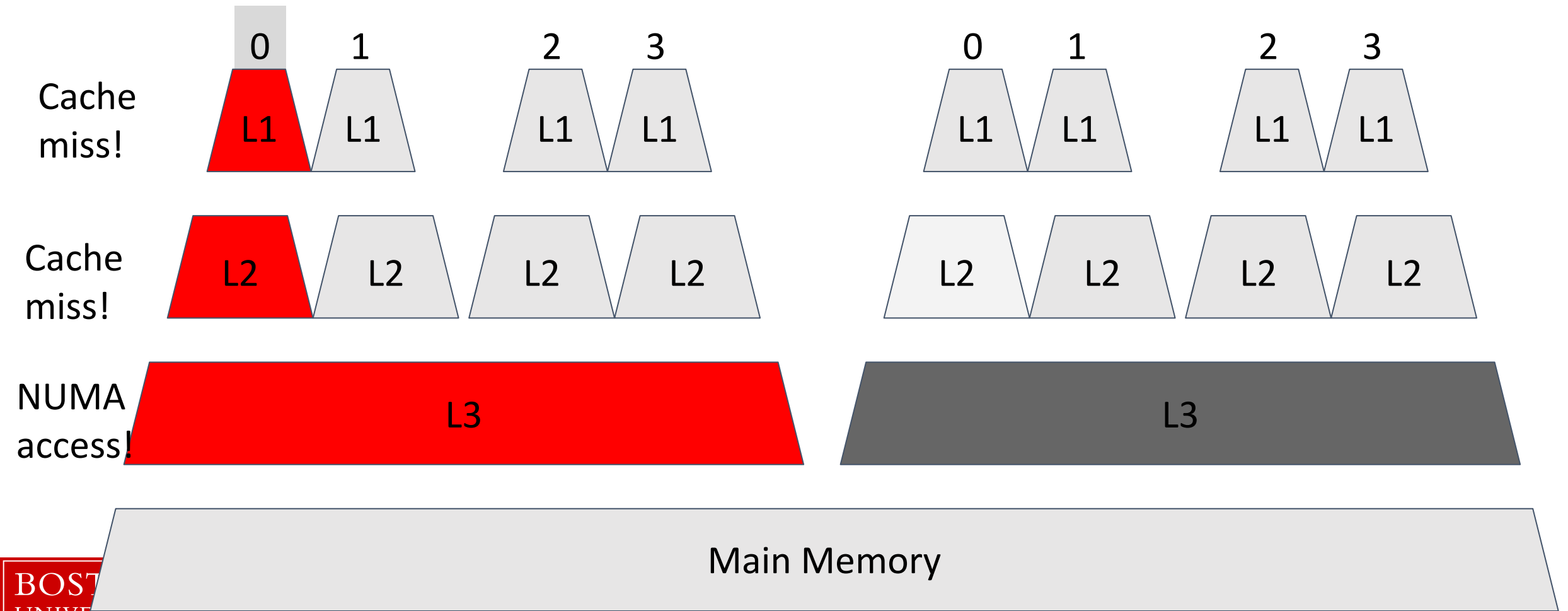

Why knowing the cache hierarchy matters

```
int arraySize;
for (arraySize = 1024/sizeof(int) ; arraySize <= 2*1024*1024*1024/sizeof(int) ; arraySize*=2)
// Create an array of size 1KB to 4GB and run a large arbitrary number of operations
{
    int steps = 64 * 1024 * 1024; // Arbitrary number of steps
    int* array = (int*) malloc(sizeof(int)*arraySize); // Allocate the array
    int lengthMod = arraySize - 1;

    // Time this loop for every arraySize
    int i;
    for (i = 0; i < steps; i++)
    {
        array[(i * 16) & lengthMod]++;
        // (x & lengthMod) is equal to (x % arraySize)
    }
}
```

This machine has:
256KB L2 per core
16MB L3 per socket

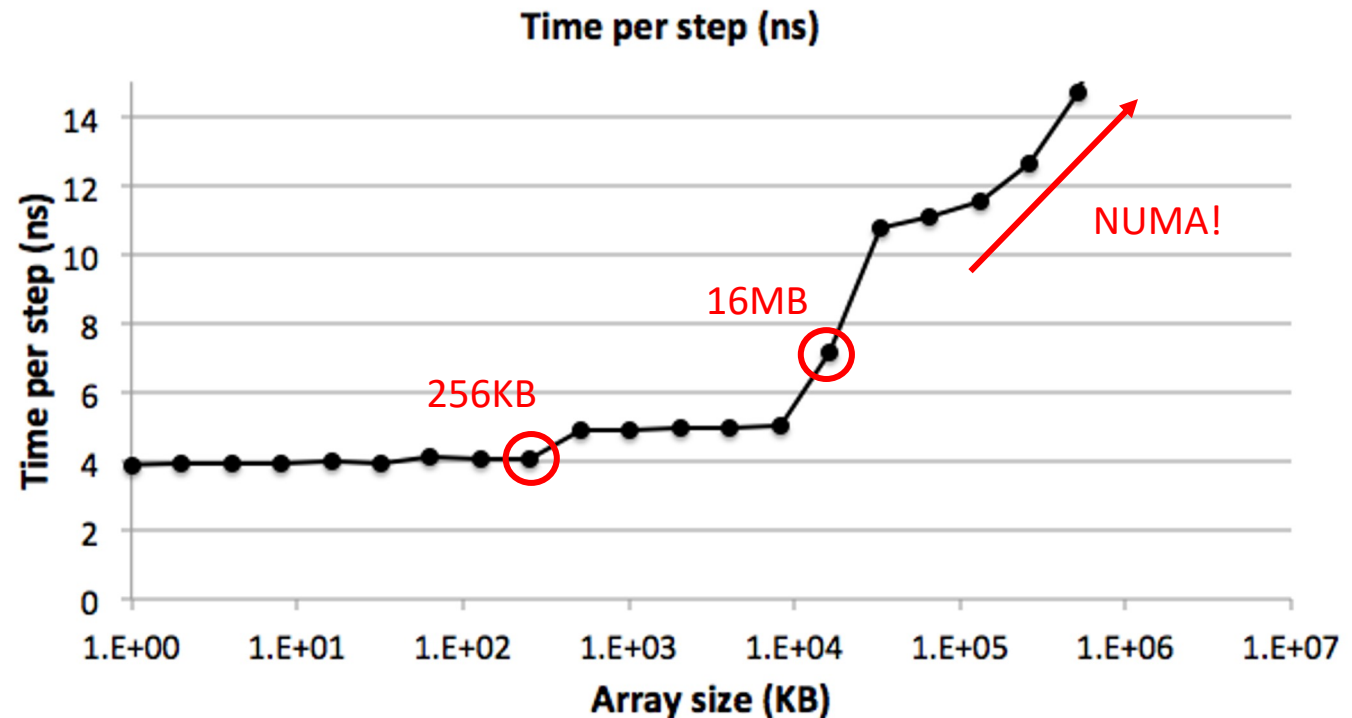

Storage Hierarchy

Why not just stay in memory?

Historical Cost of Computer Memory and Storage

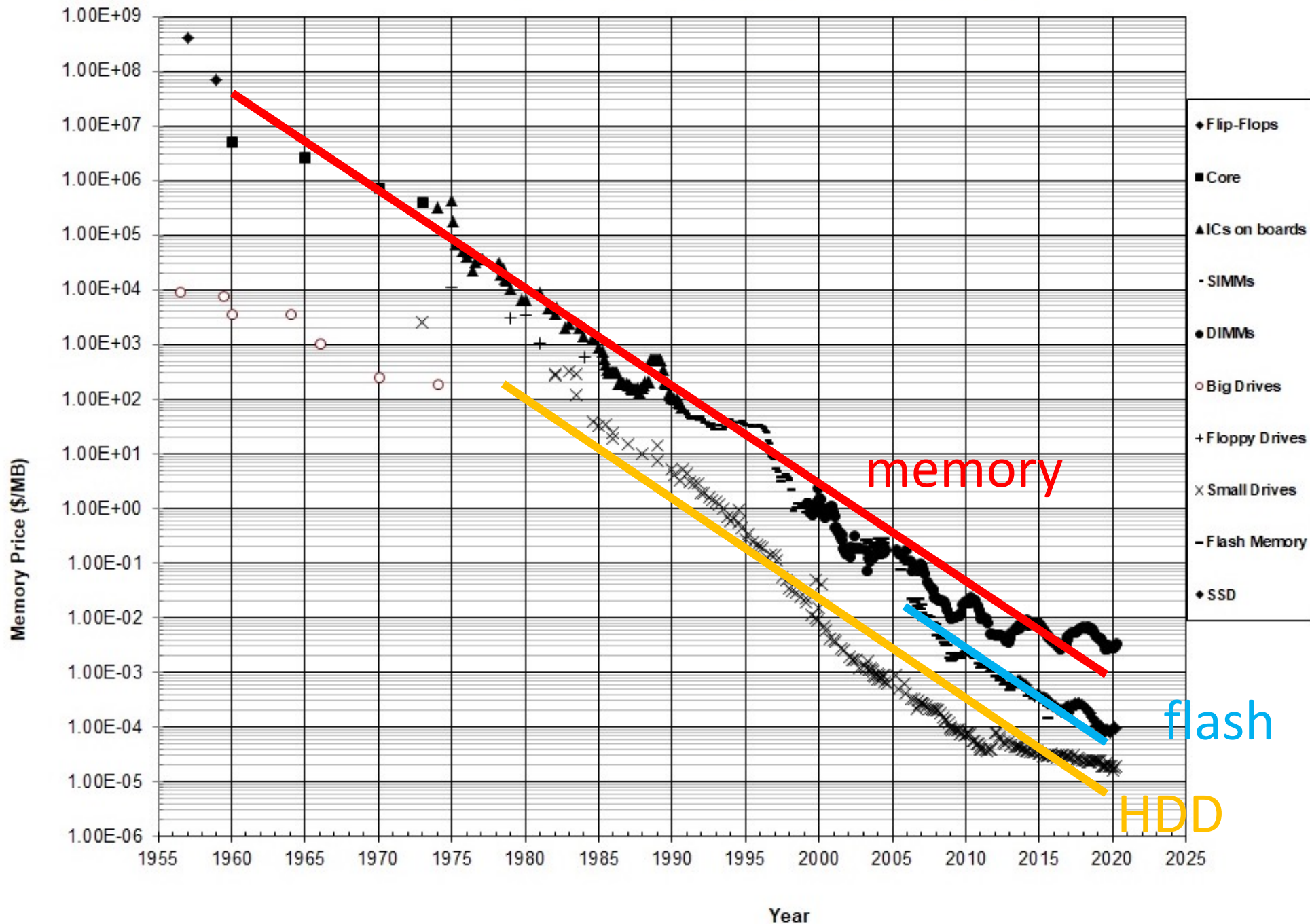

Cost!

what else?

Storage Hierarchy

Why not stay in memory?

Rephrase: what is missing from memory hierarchy?

Durability (data survives between restarts)

Capacity (enough capacity for data-intensive applications)

Storage Hierarchy

Main Memory

SSD (Flash)

HDD

Shingled Disks

Tape

Storage Hierarchy

Main Memory

SSD (Flash)

HDD

Shingled Disks

Tape

Hard Disk Drives

Secondary durable storage that support both *random* and *sequential* access

Data organized on pages/blocks (across tracks)

Multiple *tracks* create an (imaginary) *cylinder*

Disk access time:

seek latency + rotational delay + transfer time
(0.5-2ms) + (0.5-3ms) + <0.1ms/4KB

Sequential >> random access (~10x)

Goal: avoid random access

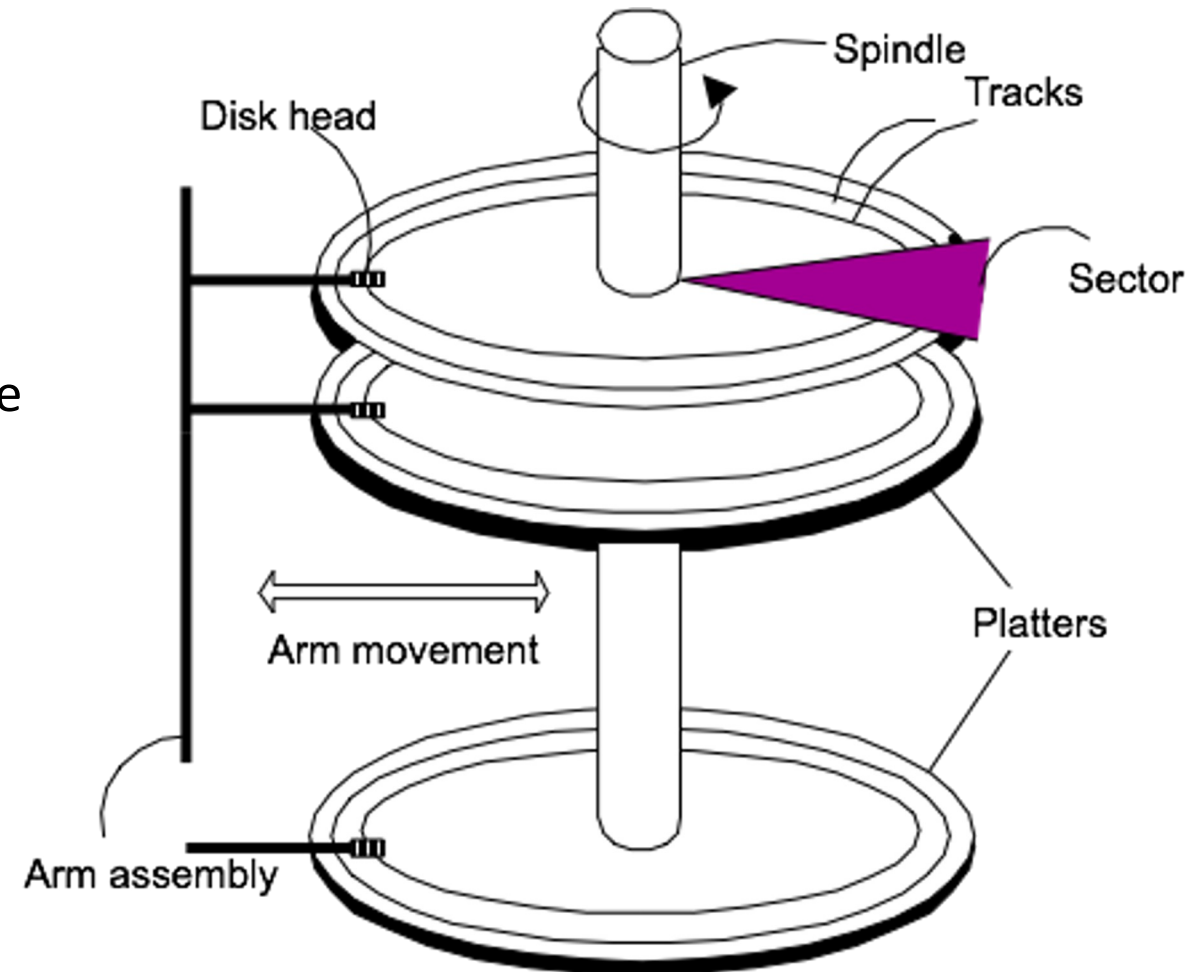

Seek time + Rotational delay + Transfer time

Seek time: the **head** goes to the right **track**

Short seeks are dominated by “settle” time (D is on the order of hundreds or more)

Rotational delay: The **platter** rotates to the right **sector**.

What is the min/max/avg rotational delay for 10000RPM disk?

min: 0, max: $60s/10000=6ms$, avg: 3ms

Transfer time: $<0.1ms$ / page \rightarrow more than 100MB/s

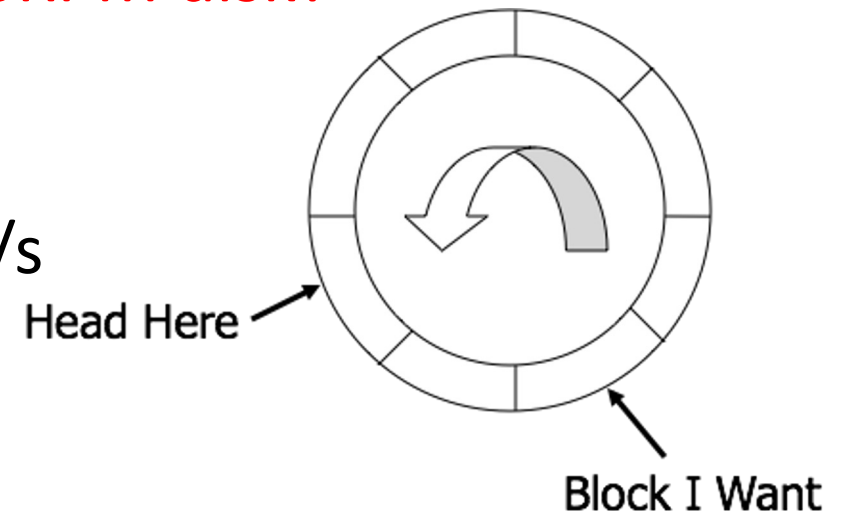
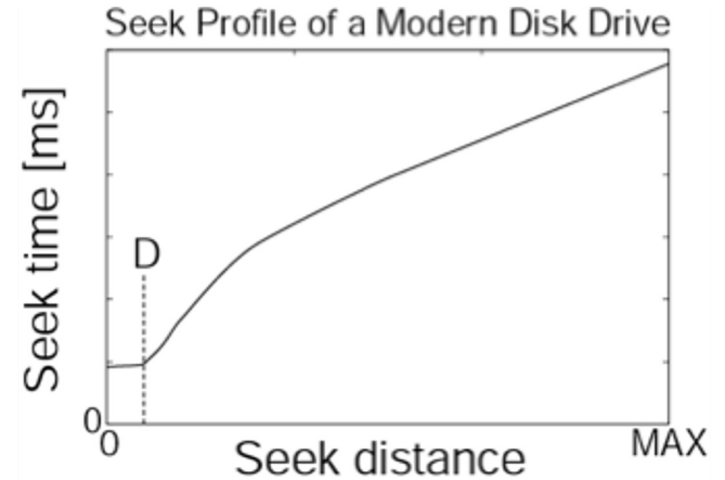

Sequential vs. Random Access

Bandwidth for Sequential Access (assuming 0.1ms/4KB):

0.04ms for 4KB → **100MB/s**

Bandwidth for Random Access (4KB):

0.5ms (seek time) + 3ms (rotational delay) + 0.04ms = 3.54ms

4KB/3.54ms → **1.16MB/s**

Flash

Secondary durable storage that support both *random* and *sequential* access

Data organized on pages (similar to disks) which are further grouped to erase blocks

Main advantage over disks: random read is now much more efficient

BUT: Not as fast random writes!

Goal: avoid random writes



The internals of flash

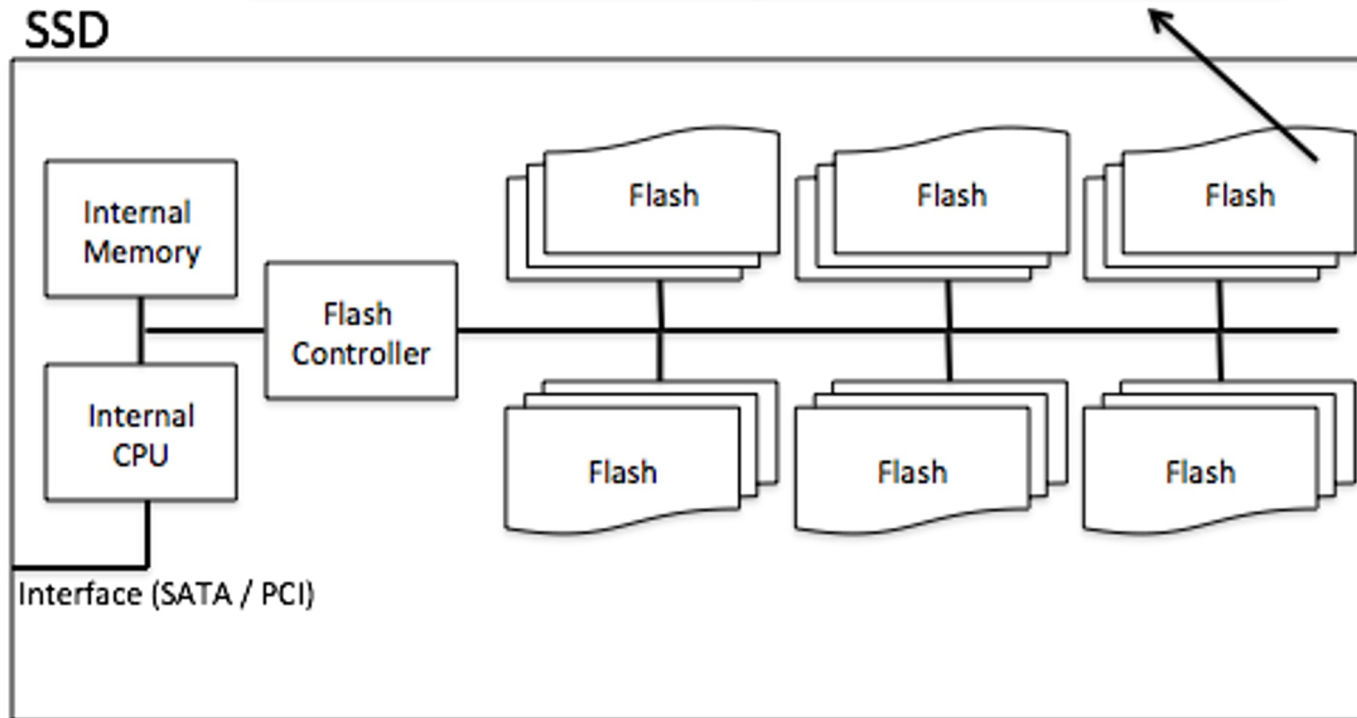
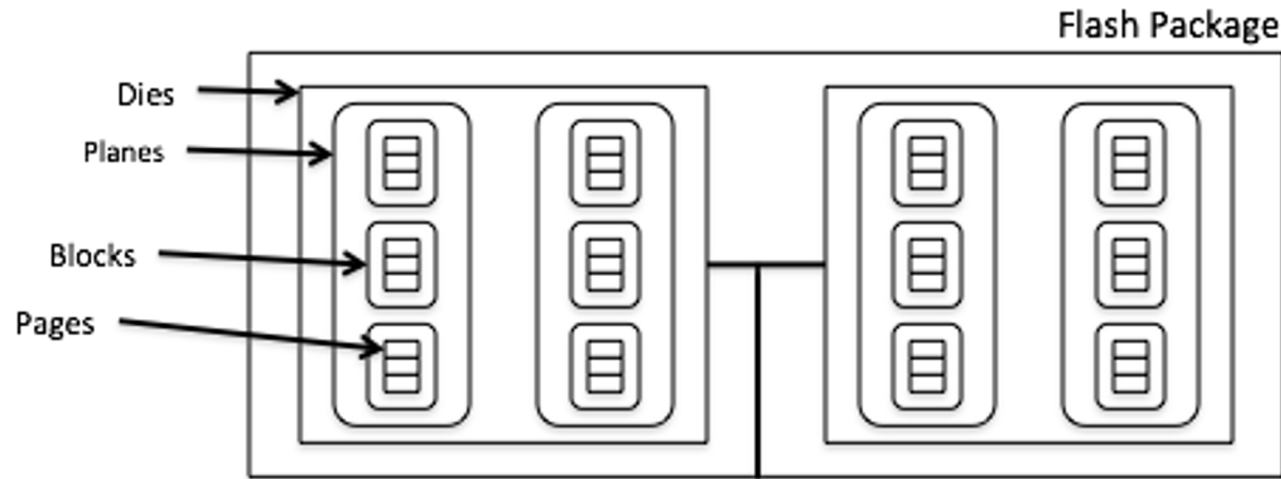

interconnected flash chips

no mechanical limitations

maintain the block API
compatible with disks layout

internal parallelism
for both read/write

complex software driver

Flash access time

... depends on:

device organization (*internal parallelism*)

software efficiency (*driver*)

bandwidth of flash packages

the Flash Translation Layer (FTL), a complex device driver (firmware) which tunes performance and device lifetime

Flash vs HDD

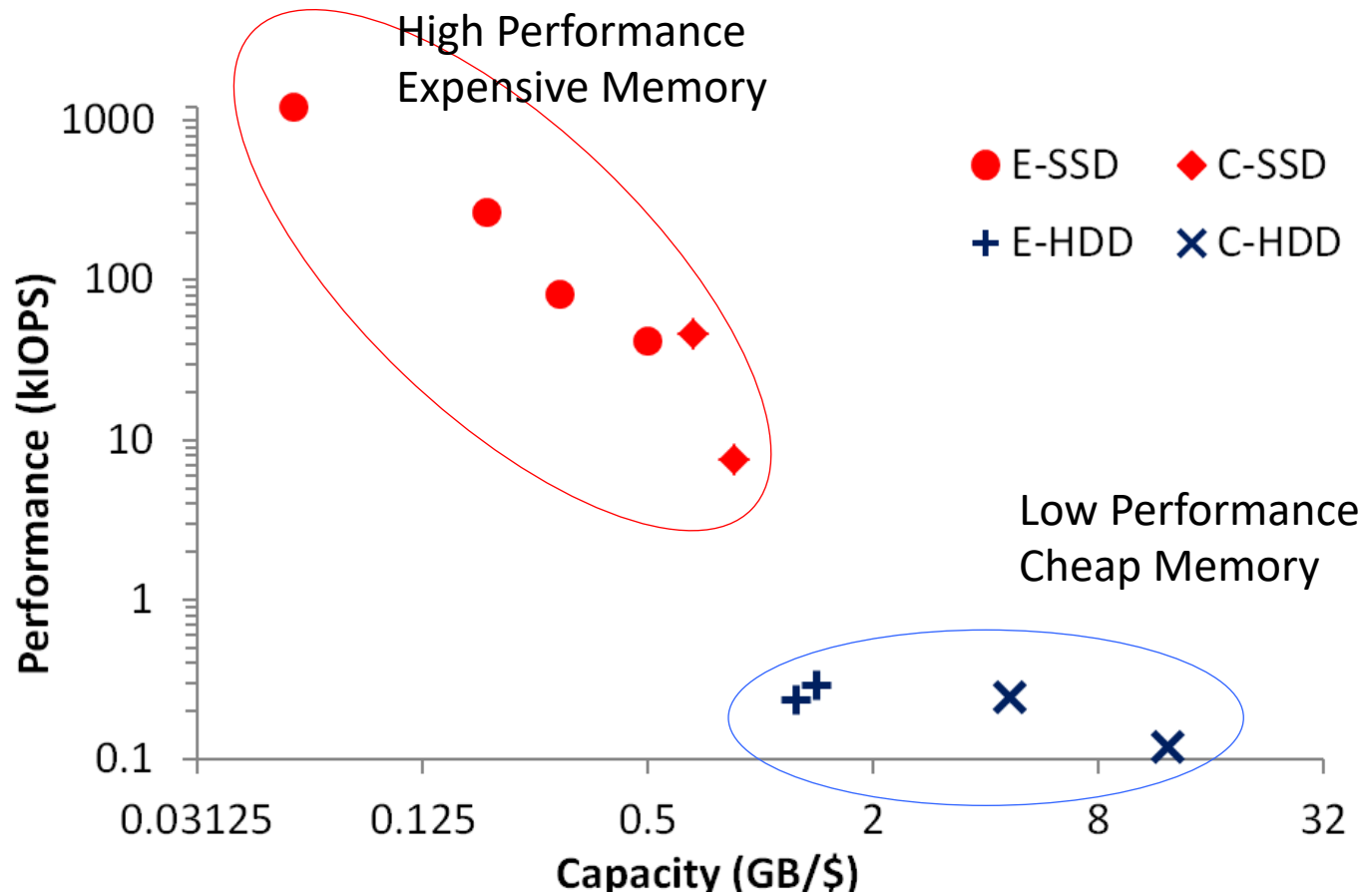

HDD

✓ Large - cheap capacity

✗ Inefficient random reads

Flash

✗ Small - expensive capacity

✓ Very efficient random reads

✗ Read/Write Asymmetry

Storage Hierarchy

Main Memory

Flash

HDD

Shingled Disks

Tape

Tapes

Data size grows exponentially!

Cheaper capacity:

Increase density (bits/in²)

Simpler devices

Tapes:

Magnetic medium that allows
only **sequential access**
(yes like an old-school tape)!

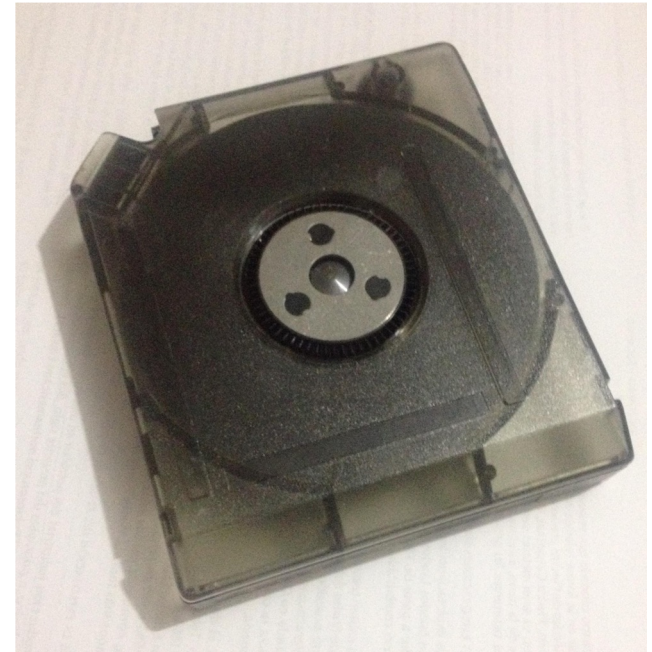

Increasing disk density

Very difficult to differentiate between tracks
“settle” time becomes

Writing a track affects neighboring tracks
Create different readers/writers
Interleave writes tracks

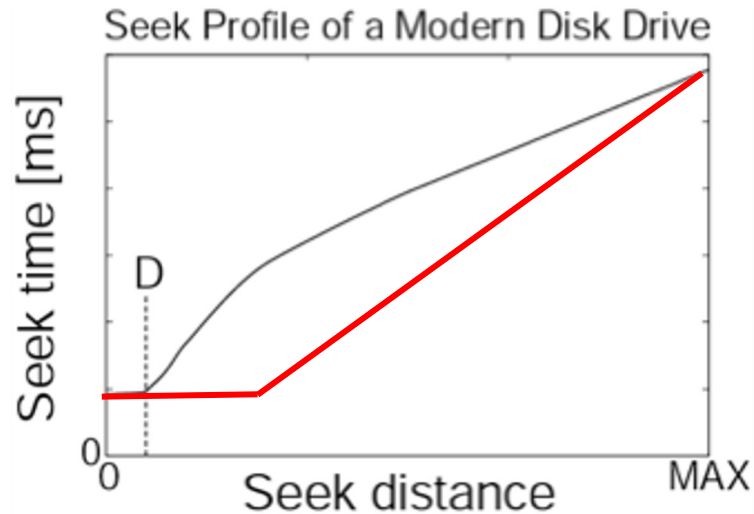

Conventional Writes



SMR Writes

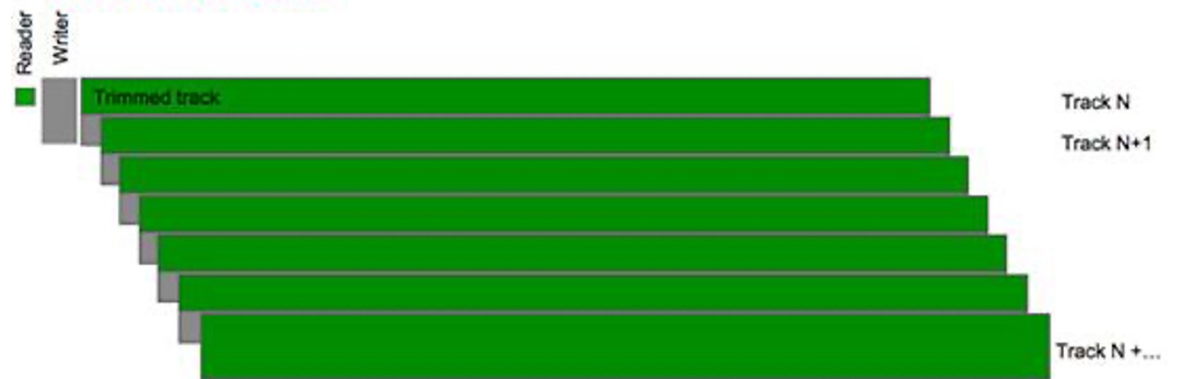

Memory & Storage Walls

Memory Wall

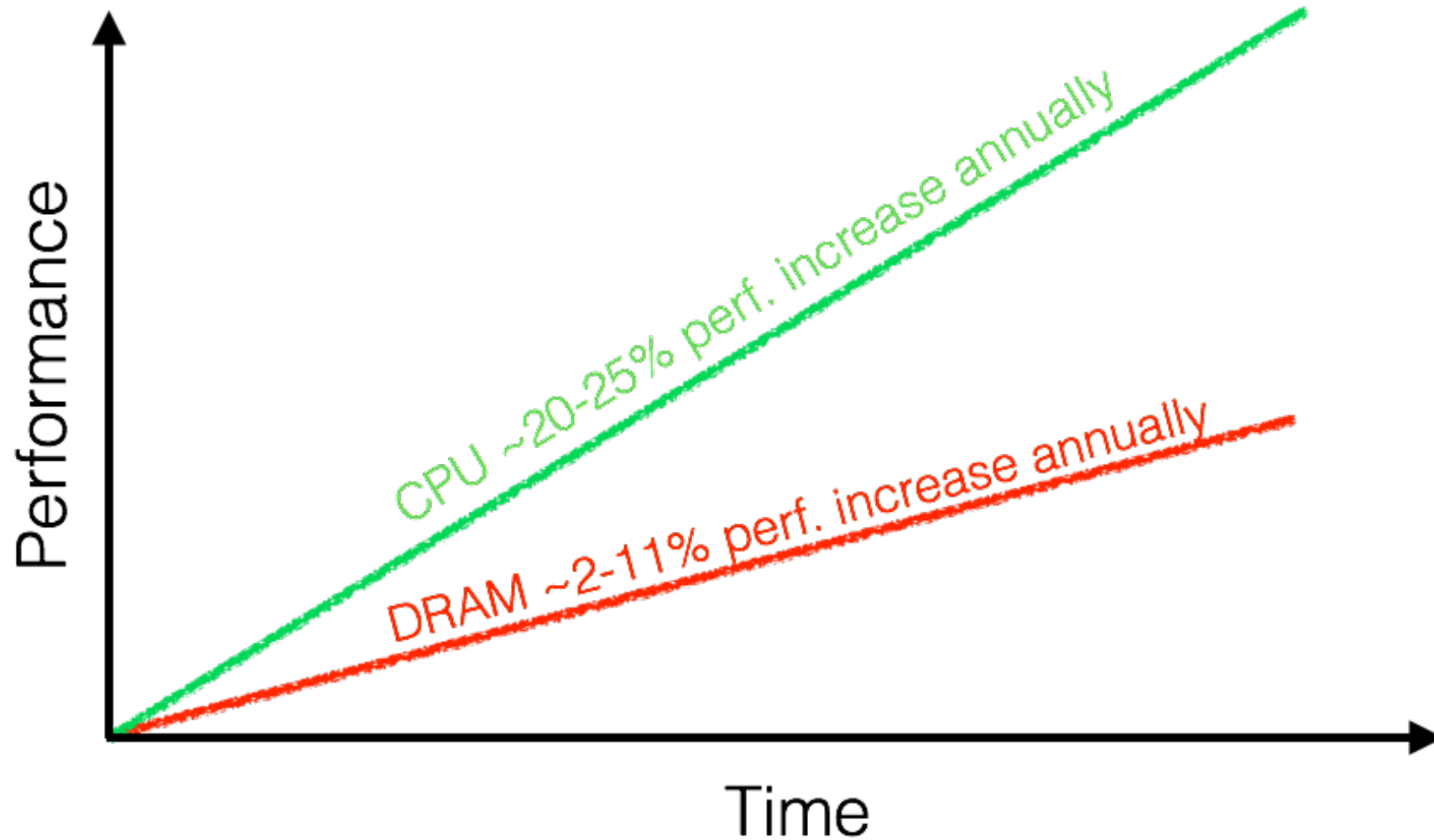

Memory Wall

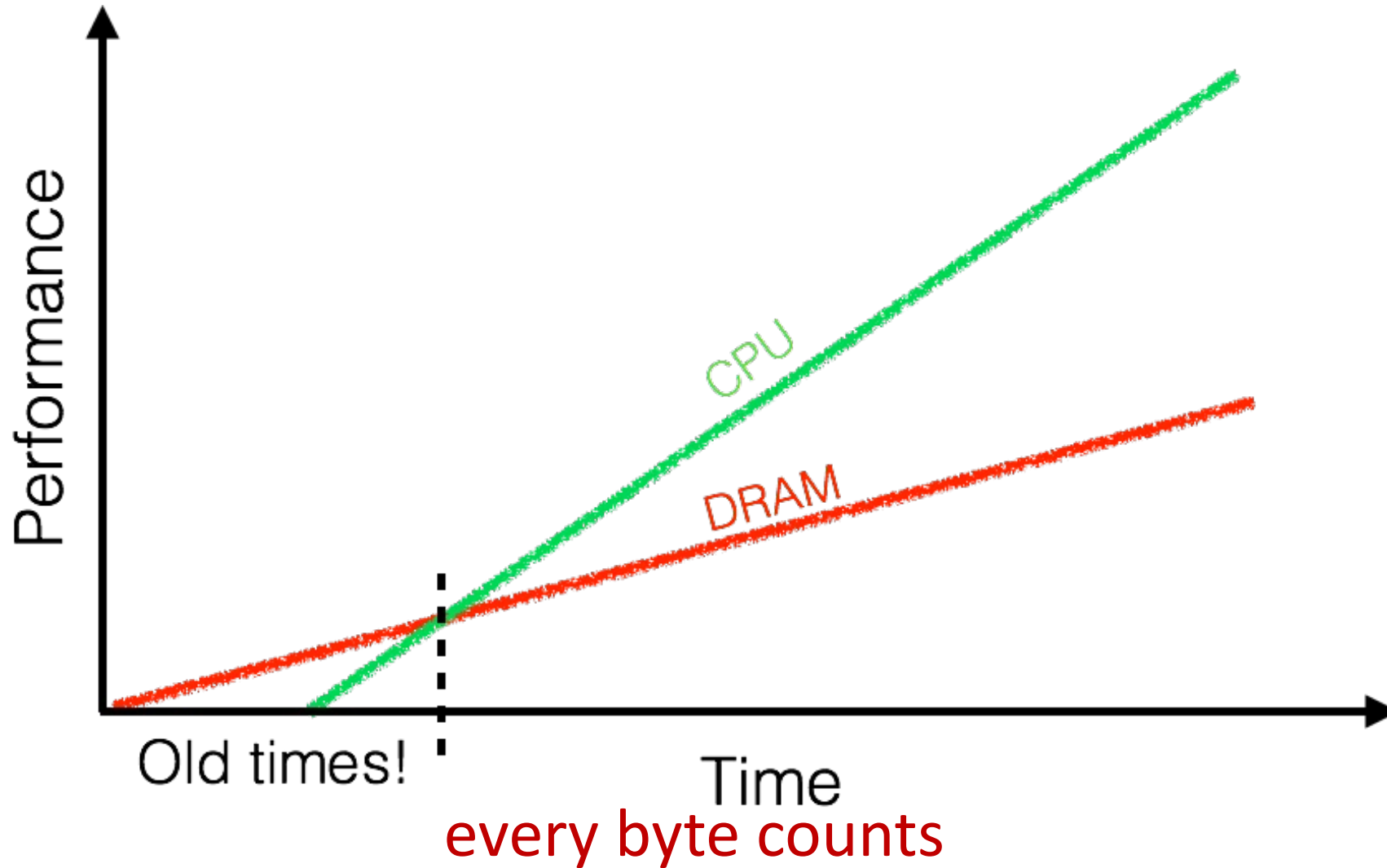

Storage Wall



HDD

- ✓ capacity
- ✓ sequential access
- × random access
- × latency plateaus

Evolution of hard disks

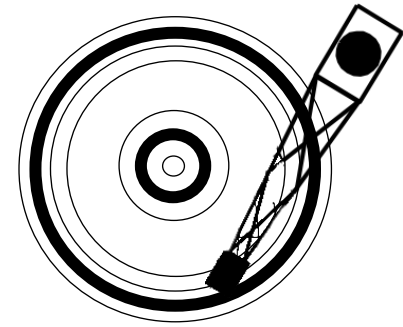

disks become larger but – relatively – slower

Storage Wall

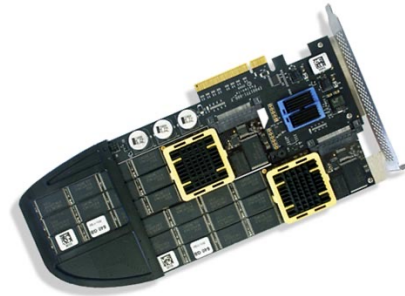

HDD

- ✓ capacity
- ✓ sequential access
- × random access
- × latency plateaus

SSD (Single Level Cell)

- ✓ random reads
- ✓ low latency
- × capacity
- × endurance
- × read/write asymmetry

SSD (Multi Level Cell)

- ✓ capacity
- × endurance (worse)

“Tape is Dead, Disk is Tape, Flash is Disk” [Jim Gray 2007]

- Storage without mechanical limitations

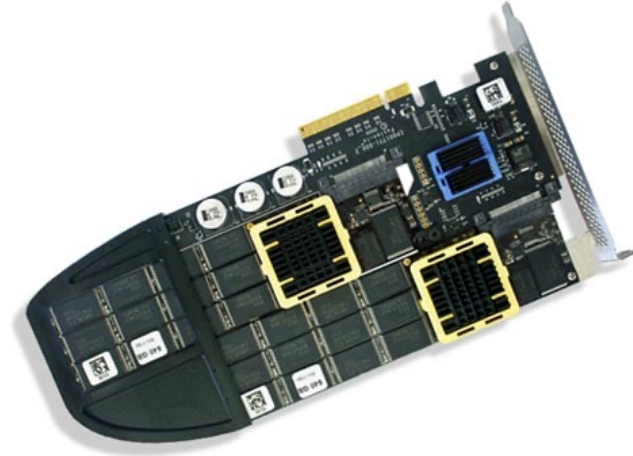

Several technologies

- Flash
- Phase Change Memory (IBM)
- Memristor (HP)

flash vs. hard disks?

Flash vs. HDD

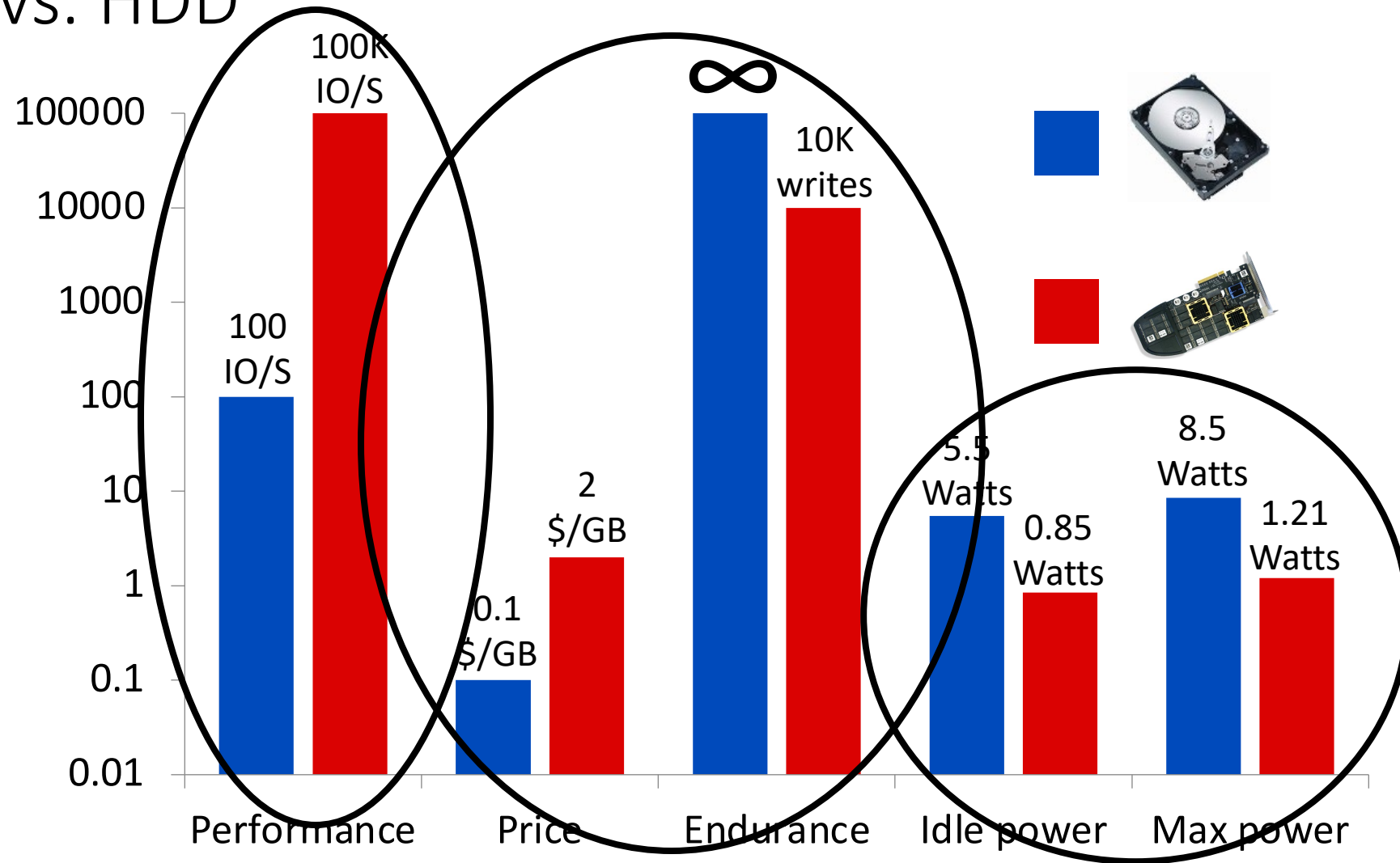

read, update, storage tradeoffs

Storage Wall



HDD

- ✓ capacity
- ✓ sequential access
- × random access
- × latency plateaus



SSD (Single Level Cell)

- ✓ random reads
- ✓ low latency
- × capacity
- × endurance
- × read/write asymmetry

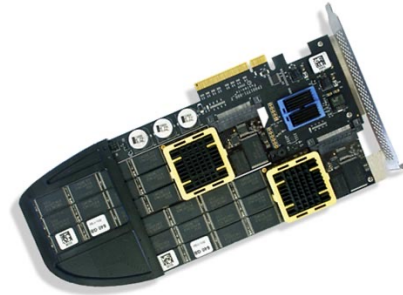

SSD (Multi Level Cell)

- ✓ capacity
- × endurance (worse)



HDD (Shingled Magnetic Rec.)

- ✓ capacity
- × read/write asymmetry

every byte counts

Technology Trends & Research Challenges

- (1) From fast **single cores** to **increased parallelism**
- (2) From **slow storage** to **efficient random reads**
- (3) From **infinite** endurance to **limited endurance**
- (4) From **symmetric** to **asymmetric read/write performance**

Technology Trends & Research Challenges

How to exploit increasing parallelism (in compute and storage)?

How to redesign systems for efficient random reads?

e.g., no need to aggressively minimize index height!

How to reduce **write amplification** (physical writes per logical write)?

How to write algorithms for asymmetric storage?

Even faster devices are available (NVMe)

How to use them when the software stack is too slow?

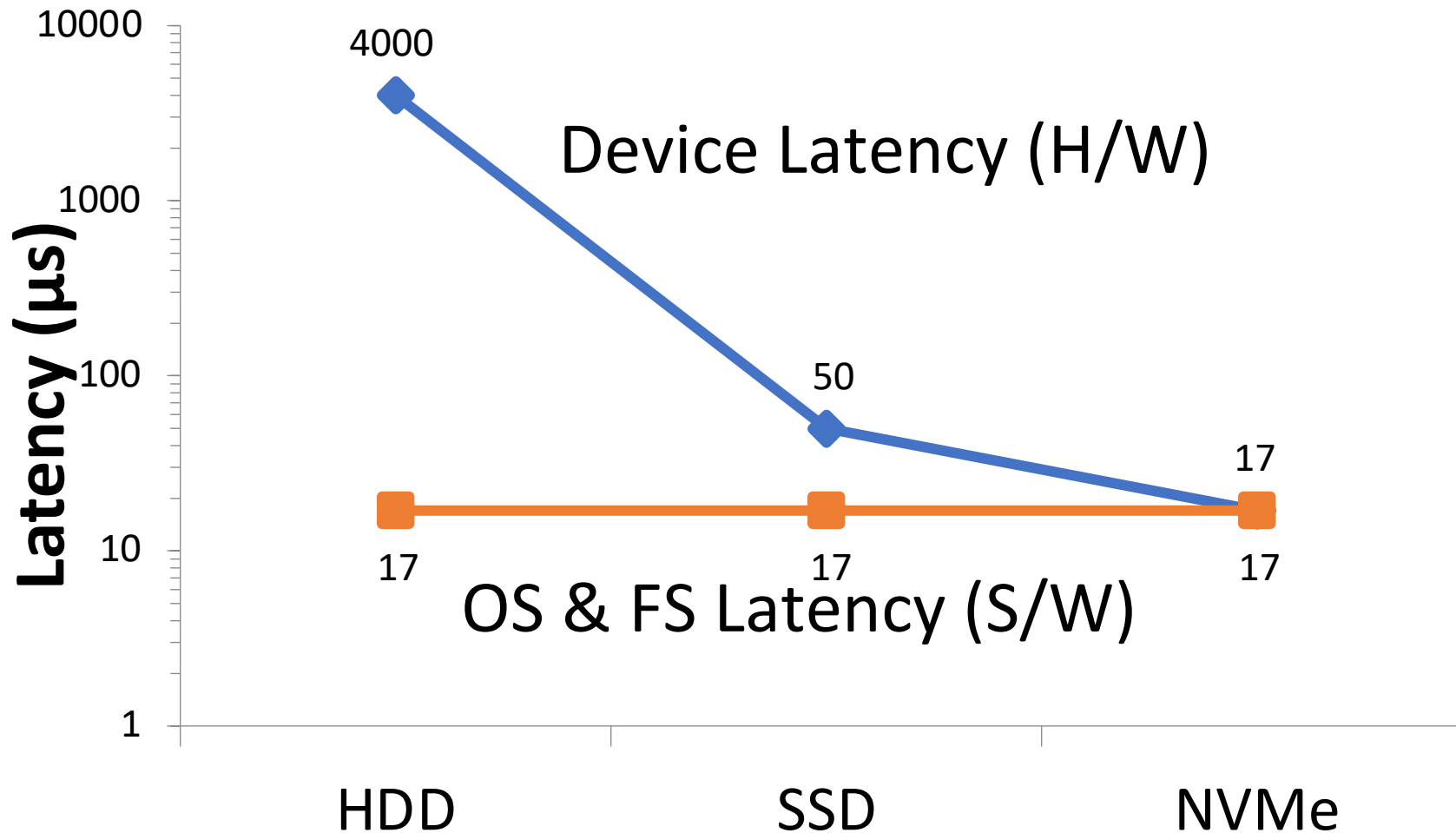

Class 15

Data Systems on Modern Hardware:
Multi-cores, Solid-State Drives, and Non-Volatile Memories

Tarikul Islam Papon

<https://bu-disc.github.io/CS561/>